

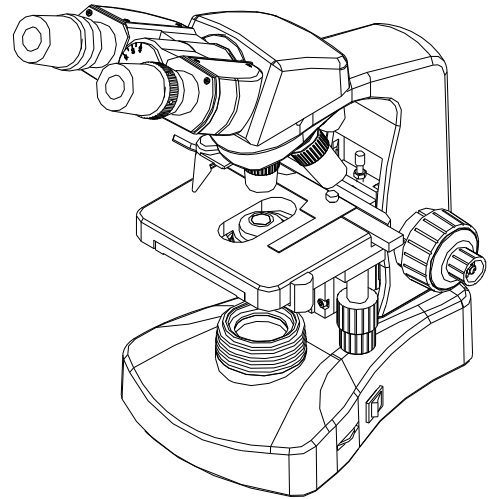

Biological Microscope

Model: BS-2020B/T

Instruction Manual



This manual is written for biological microscope BS-2020B/T. To ensure the safety, obtain optimum performance and to familiarize you fully with the use of this microscope, it is recommended strongly that you study this manual thoroughly before using the microscope and retain this manual in an easily accessible place near the work desk for future reference.

User Notices	2
1 Components Name	4
2 Installation	5
2.1 Installing Diagram	5
2.2 Installing Steps	6
3 Adjustment & Operation	10
3.1 Adjustment Controls	10
3.2 Operation	11
4 Technical Specifications	14
5. Outfit Table	15
6 Troubleshooting	16

I. Safety note

1. Carefully open the box, avoid the accessories, like lens, dropping to ground and being damaged.
2. Do keep the instrument out of direct sunlight, high temperature or humidity, dusty and easy shaking environment. Make sure the stage is smooth, horizontal and firm enough.
3. When moving the instrument, please use two hands to grip with the two sides of the microscope body.
4. When running, the lamp house and nearby parts will be very hot. Please ensure there is enough cooling room for them.
5. Make sure the instrument is earthed, to avoid lighting strike.
6. For safety, be sure the main switch is in “O”(off) state before replacing the halogen (LED) lamp or the fuse, then cut off the power, and do the operation after the lamp bulb and the lamp house completely cool.(specified lamp: Halogen Lamp 6V/20W or LED lamp 3W)
7. Check the input voltage: be sure the input voltage which signed in the back of the microscope is consistent with the power supply voltage, or it will bring a serious damage to the instrument. Use the factory supplied power cord, please.

II. Maintenance

1. All the lenses have been well checked and adjusted. It is forbidden to disassemble them yourself.
2. The nosepiece and coarse/fine focus unit have a compact and precise frame, please don't disassemble them as possible as you can.
3. Keep the instrument clean, wipe dust regularly, and be attention to avoid contaminating the optical elements especially.
4. The contaminations on the prism, as finger mark and oil, could be gently wiped with a piece of soft cloth or tissue paper, gauze which has been immersed in pure alcohol or xylene. **(note that the alcohol and the xylene are all burned easily, do not let them near the fire, and use them in a drafty room as possible as you can.)**
5. Don't use organic solvent to wipe the non-optical elements, when you need to clean, use the soft detergent, please.
6. When using, if the microscope is splash by liquid, cut off the power at once, and wipe up the moisture.
7. Do not disassemble any parts of the microscope. That will affect the function or decline the performance of the microscope.
8. Place the instrument in a cool, dry position. After using the microscope, remember to cover it with dust helmet. Do wait for the lamp house cooling completely before cover.

1. Name of Components

BS-2020

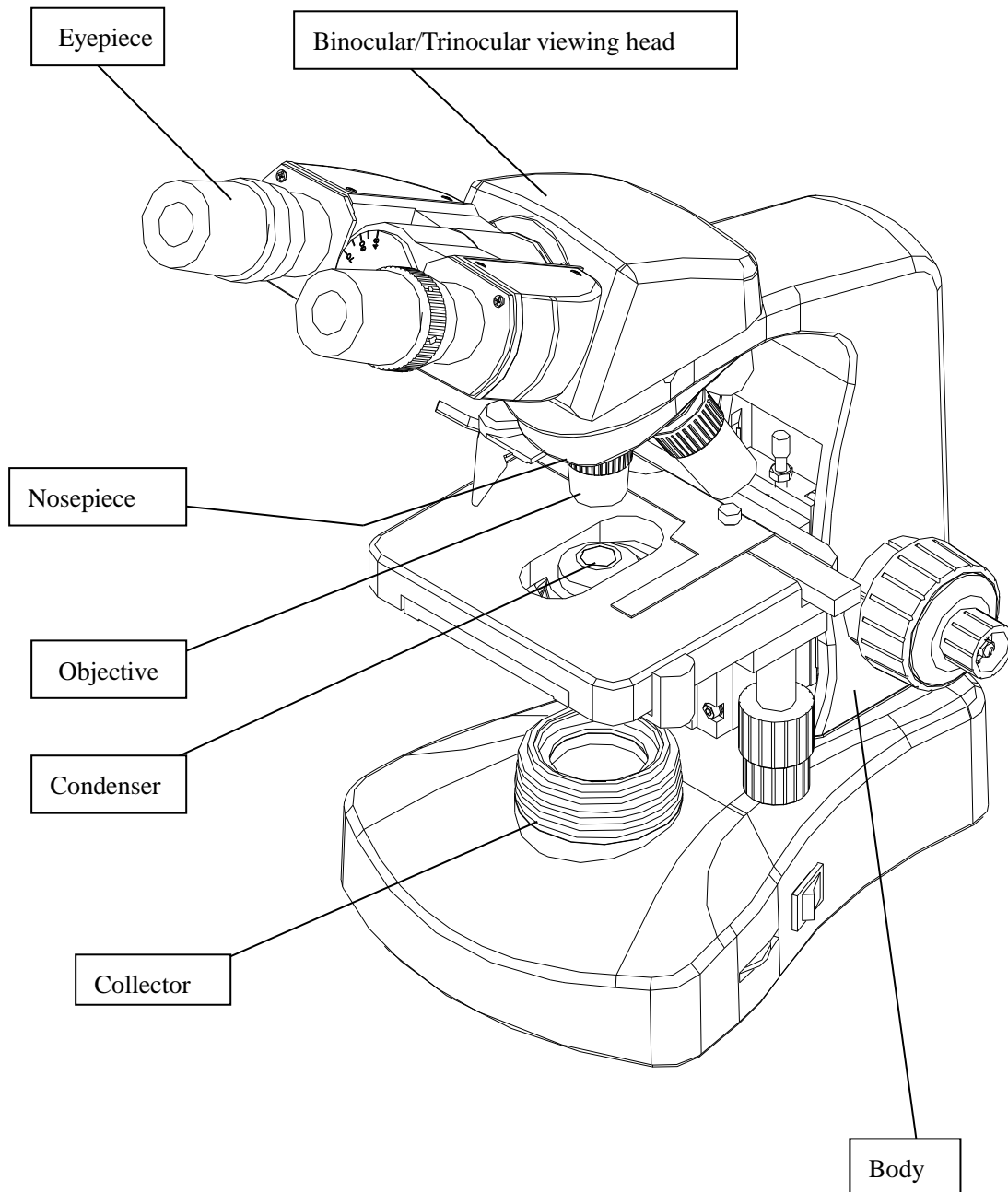

Biological Microscope BS-2020B

2. Installation

BS-2020

2.1 Installing Diagram

The following figure shows the installation sequence of the components. The number in the figure shows the assembly steps.

- ★ Before installing, be sure every components is clean, do not score any parts or glass surface.
- ★ Keep well with hexagon wrench provided. When replacing the components, you will need it again.

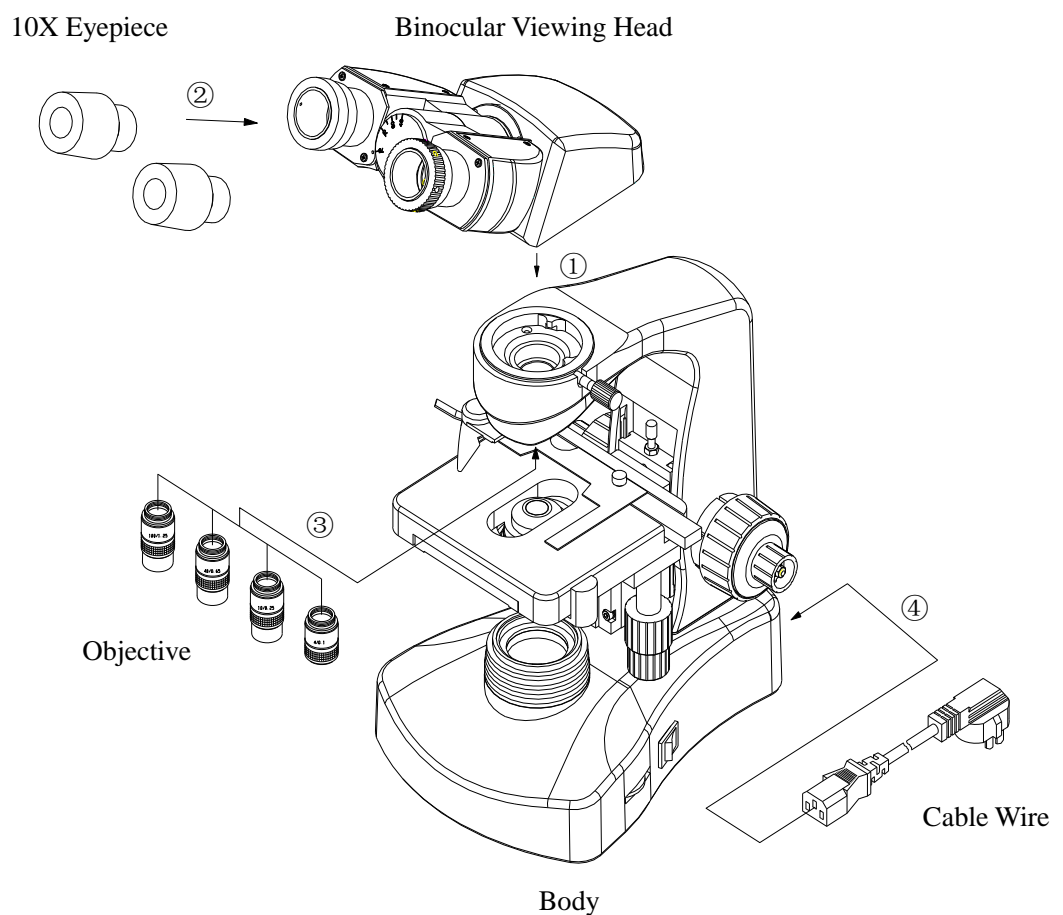

2.2 Installing Setps

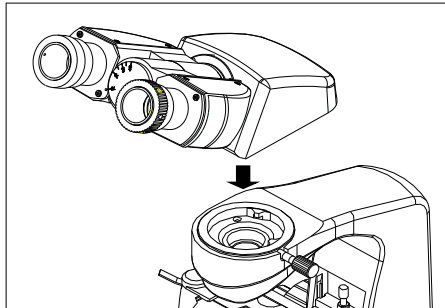

Fig.1

2.2.1 Install the binocular viewing head (Fig.1-2)

Insert the binocular viewing head into the head of the body, turn to the right position, then fix up it with bolt①.

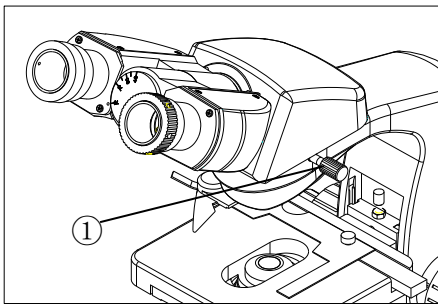

Fig.2

2.2.2 Install the eyepiece (Fig.3-4)

Insert the eyepieces into the eyepiece tube until they are against each other.

Fig.4 shows the status after the installation.

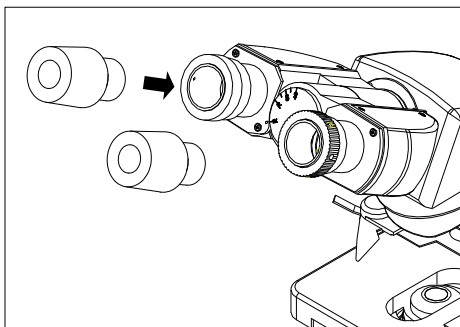

Fig.3

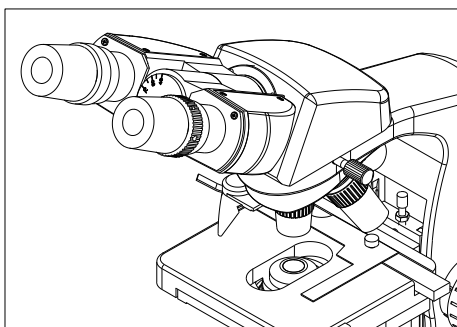

Fig.4

Note:

Working Environment Requirement:

1. Ambient temperature: 5° C to 40° C . (41° F to 104° F), Maximum R.H: 85% .
2. High Temperature will result in a mildewing, dew and even ruinous instrument.
3. Avoid placing the instrument in a dusty environment. When ending your microscope operation, please cover it with the dust cover.
4. Lay the microscope in a plan and stable position please.

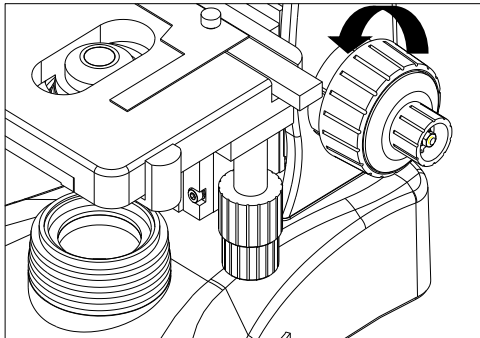

Fig.5

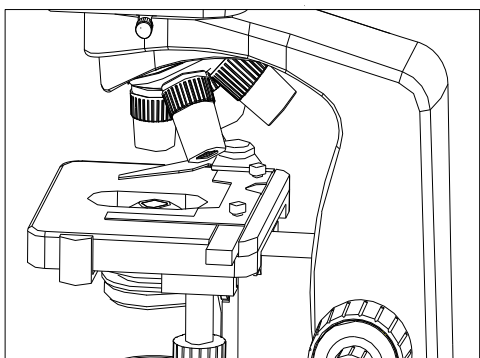

Fig.6

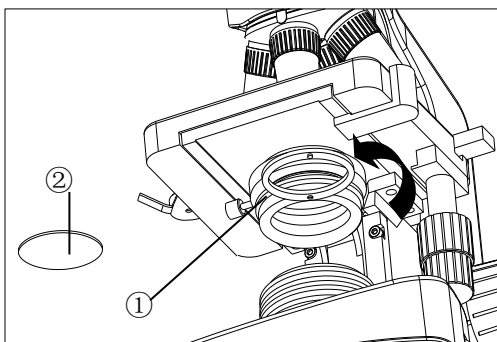

Fig.7

2.2.3 Installing the Objective (Fig.5-6)

1. Adjusting the coarse focus knob until the support device of the mechanical stage reaches its low limit position.
2. Screw the lowest magnification objective into the nosepiece from the left or the right side, then revolve the nosepiece clockwise and mount other objectives in sequence of magnification.

◇ Installing objective this way will make the change of magnification easier during using.

★ Clean the objectives regularly, for lens is susceptible to dust.

★ When operating, use 10× magnification objective to search and focus specimen firstly, then replace with higher magnification objective if necessary.

★ When replacing the objective, slowly turn the nosepiece until you hear “clicked”, which means the objective is in the required position—center of the light path.

2.2.4 Install the color filter (Fig.7)

1. Rotate the condenser holder① out as Fig.7 shows.
2. Put the filter② into the condenser holder, and then switch back the holder.

★ Baby blue and green filters are available in standard outfit.

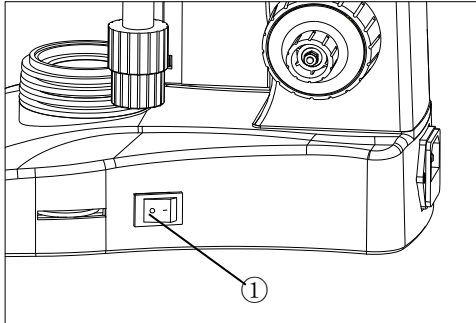

Fig.8

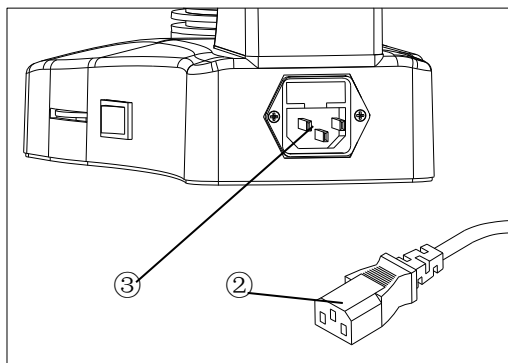

Fig.9

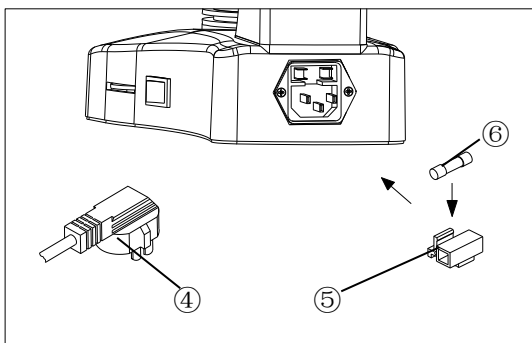

Fig.10

2.2.5 Connecting the Power Cord

(Fig.8-10)

★ The cable and cords are vulnerable when bent or twisted, never subject the power cord to excessive force.

1. Before connecting the power cord, switch the main switch① to “O”(off).
2. Plug the power cord② into the socket③ on microscope safely. Make sure the connection is well.
3. Plug the power cord④ into the power source socket safely. Make sure the connection is well.

★ Do use the supplied power cord all the time. If lost or damaged, select the same standard cord please.

★ Either 110V or 220V can be selected as the input voltage of this microscope. (The input voltage has been preset in the microscope before leaving factory.

2.2.6 Replacing the fuse (Fig.7, 9, 10)

Do remember to turn the main switch① off before replacing the fuse, and unplug the power cord②. Dig the fuse⑤ kits out of the power source socket③ with your fingers, replace with a new fuse, then insert it back to the power source socket again.

★ 250V500mA fuse for 220V.

7 ★ 250V1A fuse for 110V.

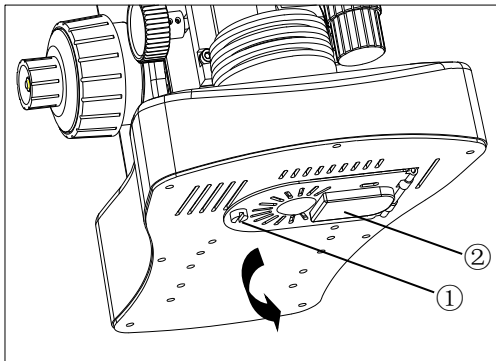

Fig.11

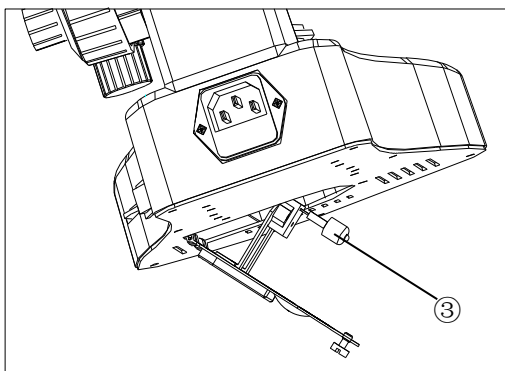

Fig.12

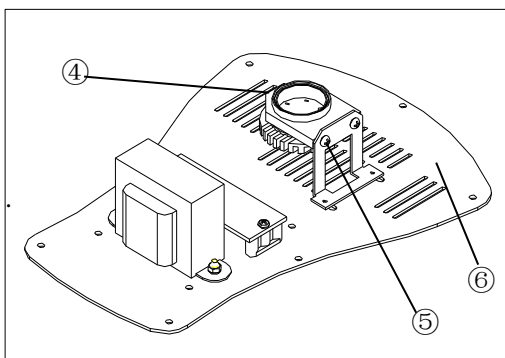

Fig.13

2.2.8 Installing and replacing the lamp (Fig.11, 12, 13)

0.246810✧ There are two types of lamp for illumination, halogen Lamp 6V/20W and LED lamp 3W.

When changing halogen lamp:

1. When being used, or soon after it is turned off, the lamp, the lamp house and nearby parts will be very hot and will cause serious burns. Please turn the main switch on “O” (off), pull up power plug, and make sure the bulb, the lamp house and periphery are all cool. Then, you can do your replacing.
2. Loosen the bolt① on the lamp holder window at the base of the microscope by screwdriver, screw lamp holder window② out.
3. Pull out the halogen bulb③, hold the bulb after you wrap it with gauze or other protection materials, then depress the plugs into the jack on the lamp house.
4. Finally, cover the lamp holder window, screw down the bolt①.

★ Please insert the lamp gently, or it will be damaged by excessive extrusion.

★ Do not touch the Halogen bulb with your hands. It will shorten the service life or cause it to burst. If you leave fingerprints on the surface carelessly, clean it with a dry soft cloth.

When changing LED lamp:

1. The working life of LED lamp is very long, so it is hard to be damaged, if the bulb is unfortunately damaged, please purchase a new one from supplier.
2. Removing the bottom board⑥ on the base of microscope by screwdriver, after removing the bolt⑤, LED bulb can be taken down, replaced with a new one, the new bulb should be fixed on holder with bolt⑤.
3. Fixing the bottom board to the base of microscope with the original bolt.

✧ Please take down the bottom board slowly when removing it, or the inside electrical wire may be damaged.

3. Adjustment & Operation

BS-2020

3.1 Adjustment Set Diagram (Fig.14-15)

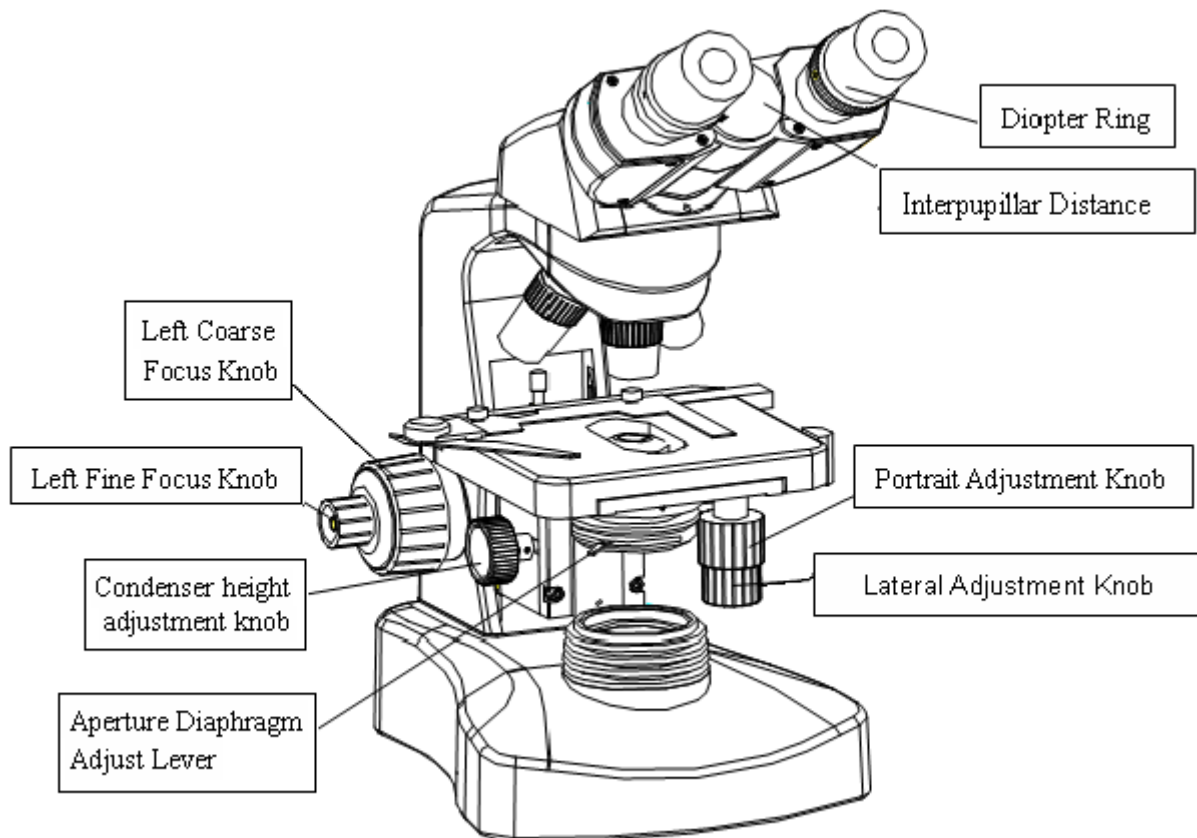

Fig.14

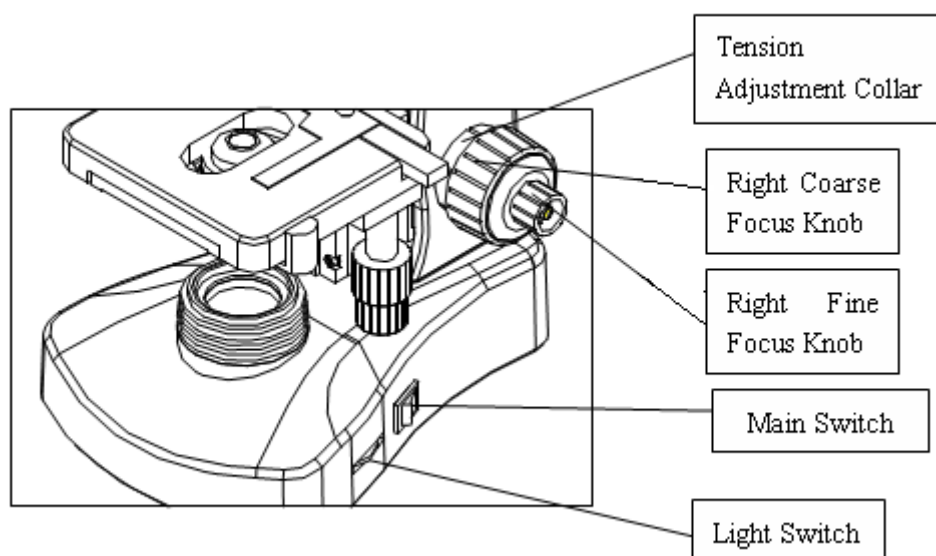

Fig.15

3.2 Operation

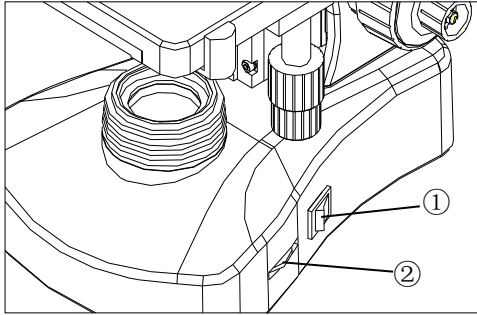

Fig.16

3.2.1 Adjusting the brightness (Fig.16)

1. Connect the power, turn on the main switch ① (figure 16) to “-”(on).
2. Turning the brightness adjustment knob② anti-clockwise, the voltage raise, and the brightness strengthen; turning it clockwise, the voltage decline, and the brightness weaken.

✧ Using the lamp in a low voltage condition will prolong the use life.

3.3.2 Placing Specimen (Fig.17)

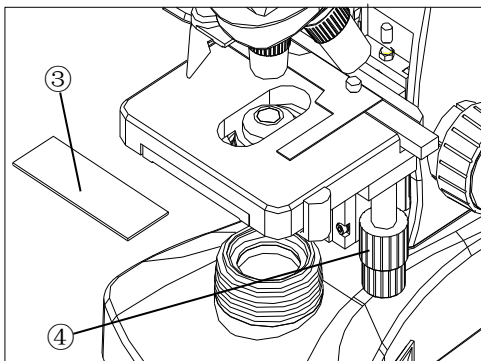

Fig.17

1. Place the slide③ on the mechanical stage. Use the slide holder to clamp the slide gently.
2. Turn the portrait and lateral adjustment knob of the mechanical ruler④, move the specimen onto the required position.

★ Be careful when changing the objective. If you finish the observation with the short working distance objective, and want to change another one, be careful of not letting the objective touch the specimen.

3.3.3 Focusing (Fig.18-19)

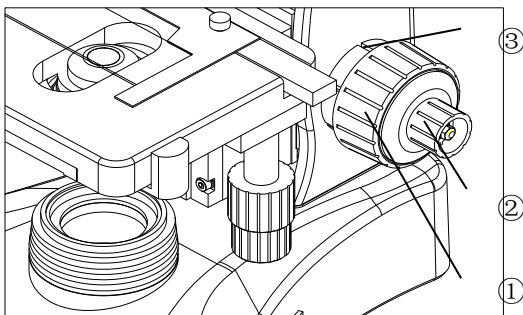

Fig.18

1. Use the 10×objective to make focus, to avoid the objective touch with the specimen, you should raise the mechanical stage at first, let the specimen close to the objective, then slowly separating them to focus.
2. The operator can conversely turn the coarse focus knob① to get the specimen down, and search images in the 10×ocular simultaneously, then use the fine knob② to focus. At this moment, you can replace other magnification objectives safely, and focus without the risk of destroying the specimen.

★ The tightness of the tension adjustment collar has been adjusted before leaving factory, if finding it's loosing (the mechanical stage drop itself because of gravity), please use the Spanner to turn the tension adjustment collar③ until the tightness is in order.



Fig.19

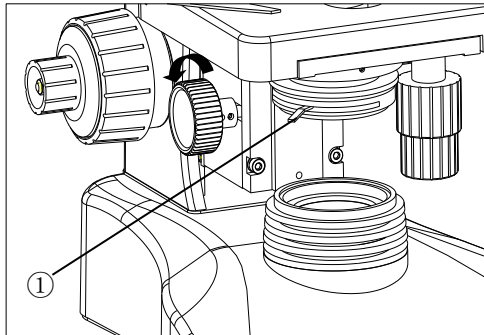

Fig.20

3.3.4 Adjusting the center and height of the condenser (Fig.20)

Rotating the focus knob of the condenser, let the condenser move up and down, let the condenser raise when we use high-power objective, and go down when we use low power objective.

- ★ The center of the condenser should be coaxial with the optical axis of objective, it has been adjusted before leaving factory, you don't need to adjust it by yourself.
- ★ The high limited place of the condenser has adjusted before leaving factory; you don't need to adjust it by yourself.

3.3.5 Adjusting the aperture diaphragm (Fig.20, 21)

Rotating the Aperture diaphragm adjust lever①, change the opening of the aperture diaphragm.

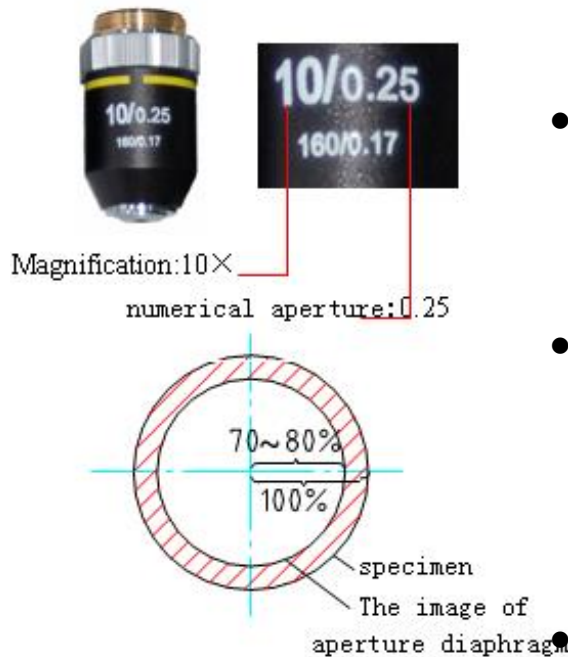

Fig.21

- If the opening of the aperture diaphragm too small, it will lead to low brightness and low resolution. But the contrast and the depth of field will increase. Reversely, if the opening of the aperture diaphragm too large, the brightness and the resolution will increase, but the contrast and depth of field will decrease.
- Generally, we can get the good quality image with sufficient contrast when the aperture diaphragm opened to the 70~80% of the objective's numerical aperture. If the opening of the aperture diaphragm too small, then it will lead to low resolution. Thus, when we observe a transparent specimen, please do not reduce the size of the aperture smaller than 60% unless we only need very low contrast. The value of the numerical aperture is signed on the tube of the each objective, for example, the sign of 10/0.25 means the magnification is 10× and the numerical aperture is 0.25mm.
- To observe the image of the aperture diaphragm, remove the eyepiece, observe the image through the tube directly.

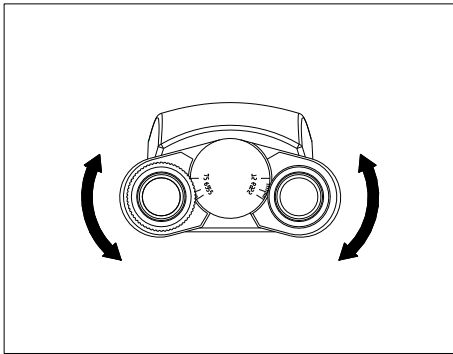

Fig.22

3.3.6 Adjusting the interpupillary distance (Fig.22)

The interpupillary distance range:

55mm~75mm.

When observing with both eyes, hold on the left and right prism holder, turn around the axis, and adjust the interpupillary distance until the left and right fields of view coincide completely.

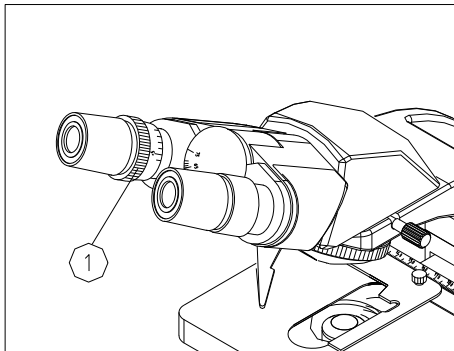

Fig.23

3.3.7 Adjusting the Diopter (Fig.23)

1. Observe the right ocular tube with your right eye. Turn the Coarse & Fine Focus Knob to bring the specimen into focus.
2. Observe the left ocular tube with your left eye. If not in focus just adjust the Diopter Ring① to make it in focus.

★ The diopter range of the eyepiece is ± 5 diopter. The value aligned to the reticle on the viewing head is the diopter in use.

4. Technical Specifications
BS-2020
(1) Main specifications

Tube Length	160mm
Viewing Head	Compensation Free Binocular Head, Inclined at 30, Interpupillary distance: 55-75mm
Eyepiece (Ocular)	Line field of view: 18mm
Nosepiece	Backward Quadruple Nosepiece
Objective	Achromatic: 4×, 10×, 40×, 100×
Focus System	Coaxial Coarse and Fine Focusing System, Sensitivity and Graduation of Fine Focus: 0.004mm, range 24mm
Condenser	Abbe NA 1.2
Stage	Double layer mechanical stage, area: 132×142mm, movement range: 75×40mm
Lamp-House	Halogen lamp 6V20W or LED lamp 3W

(2) Eyepiece, Objectives
1. Objectives

Magnification	Numerical Value Aperture Diaphragm(N.A)	Cover Glass Thickness (mm)	Focus f (mm)	Working Distance (mm)	Working Mode
4×	0.10	0.17	31.05	18	dry
10×	0.25	0.17	17.13	6.5	dry
40×	0.65	0.17	4.65	0.53	dry
100×	1.25	0.17	2.906	0.13	oil

2. Eyepiece

Kind	Magnification	Focus f (mm)	Linear Field Of View (mm)
Plan Eyepiece	10×	24.95	Φ18

3. Total magnification

Eyepiece	10×	10×	10×	10×
Objectives	4×	10×	40×	100×
Total Magnification	40×	100×	400×	1000×

5. Standard Outfit Table
BS-2020

Component name	Specification	Number	Standard outfit
Body	Frame	1	○
	Double layer mechanical stage	1	○
	Condenser holder	1	○
Viewing system	Compensation Free Binocular Head	1	○
	Monocular Head	1	Optional
Condenser	Abbe NA 1.2	1	○
Nosepiece	Quadruple Nosepiece	1	○
Lamp-House	Halogen lamp 6V20W (or LED lamp)	1	○
	Spare lamp (halogen lamp 6V20W)	2	○
	Spare fuse 50T250V2A (or 500mA)	1	○
Eyepiece	Plan 10×	2	○
Objective	Achromatic 4×	1	○
	Achromatic 10×	1	○
	Achromatic 40×	1	○
	Achromatic 100× (oil, spring)	1	○
Condenser	Bright field condenser with iris diaphragm	1	○
Filter	Blue, green	1 piece each color	○

6. Troubleshooting
BS-2020

PROBLEMS	REASON FOR PROBLEMS	SOLUTION
I . Optical Part:		
1. The edge of the field of view has shadow or the brightness is asymmetry	The nosepiece is not in the located position (The objective is not in the center of the light path)	Adjust it into the located position (turning the objective to let it in the center of the light path correctly)
	The filament shadow not in center	Adjust it to center
	The surface of the lens has contaminant (condenser, objective, eyepiece, Collector lens)	Clean the lens
2.Find dust and stain in the field of view	The surface of the lens has contaminant (condenser, objective, eyepiece, Collector lens)	Clean the lens
	There are stains on the slide	Clean the lens
	The position of condenser is too low	Loosen the bolt of the condenser, adjust its position and tighten it again
3.Bad image quality (low-resolution, bad Contrast)	No cover glass on the specimen	Add cover glass
	The cover glass is too thick or too thin	Use normal thickness cover glass(0.17mm)
	The specimen is on the reverse side	Turn it around
	Oil the dry objective (especially easy to happen on 40X)	Clean the objective
	The surface of the lens has contaminant (condenser, objective, eyepiece, Collector lens)	Clean the lens
	No oil with oil objective	Use oil
	There are air bubbles in the oil	Eliminate the bubbles
	Use the unspecified oil	Use the specified oil
	The opening of Aperture diaphragm is too large	turn it down to the proper size
	There are stains on the incidence lens of the binocular head	Clean the lens
	The opening of Aperture diaphragm is too small	Opening it to the proper size
	The position of condenser is too low	Adjust its position

4.The image one side is clear and the other side is faint	The condenser is not in the center of the field or the condenser incline	Reset the condenser and adjust the Central bolt of the condenser carefully
	The nosepiece is not in the located position	Rotate the nosepiece to the required position
	The specimen is in the floating state	Fix it firmly
5.The image move when focus it	The specimen is floating on the stage	Fix it firmly
	The nosepiece is not in the located position	Rotate the nosepiece to the required position
6. The image seems yellow slightly	Not use the blue filter	use the blue filter
7. The height of the brightness is not enough	The opening of Aperture diaphragm is too small	Adjust it again
	The position of condenser is too low	Adjust its position
	The surface of the lens has contaminant (condenser, objective, eyepiece, Collector lens)	Clean the lens

II. Mechanical Part:		
1. The image can't focus using high-power objective	The slide is on the reverse side The cover glass is too thick	Reverse the slide Use normal thickness cover glass(0.17mm)
2.The objective touch the cover glass when it change from low power to high-power	The slide is on the reverse side The cover glass is too thick	Reverse the slide use normal thickness cover glass(0.17mm)
3.The specimen moving not fluently	The slide holder is not fixed effectively	Fix it firmly
4.The left and right fields of view is not coincided.	The interpupilliary distance is not correct	Adjust it correctly
5.The eyes are uncomfortable	The diopter is not right	Adjust the diopter according your sight
	The brightness of illumination is not properly	Adjust the bulb voltage
III. Electric Part:		

1. The lamp can't light	No power supply	Check the power cord, and connect them exactly
	The installation of the bulb is wrong	Install the bulb correctly
	The bulb burn out	Change a new bulb
2. The bulb burn out suddenly	Not use the specified lamp The voltage is too high	Use the required lamp, if the situation has not change after replacing the bulb, please connect with maintenance department
3. The height of the brightness is not enough	Not use a appointed lamp The voltage is too low	Use a appointed lamp Add the voltage
4. The light glimpse	The bulb is going to spoil	Change the bulb
	The bulb is not plug in the socket correctly	Check it and plug in the socket firmly