



# BS-2027 Series Biological Microscope Instruction Manual



BS-2027M



BS-2027B



BS-2027T

This instruction manual is for the operation guide, troubleshooting and maintenance to the BS-2027 series biological microscope. Please study this manual thoroughly before operating, and keep it with the instrument. The manufacturer reserves the rights to the modifications by technology development. On the basis of operation ensured, technical specifications may be subject to changes without notice.

This product complies with Biological Microscope National Standards.

*Before Use*

|   |           |
|---|-----------|
| <b>1. COMPONENTS</b> .....  | <b>1</b>  |
| <b>2. ASSEMBLING</b> .....  | <b>3</b>  |
| <b>2-1 ASSEMBLING SCHEME</b> .....                                | <b>3</b>  |
| <b>2-2 ASSEMBLING STEPS</b> .....                                 | <b>4</b>  |
| <b>3. OPERATION</b> .....   | <b>6</b>  |
| <b>3-1 SET ILLUMINATION</b> .....                                 | <b>6</b>  |
| <b>3-2 PLACE THE SPECIMEN SLIDE</b> .....                         | <b>6</b>  |
| <b>3-3 ADJUST FOCUSING</b> .....                                  | <b>6</b>  |
| <b>3-4 ADJUST THE FOCUSING TENSION</b> .....                      | <b>7</b>  |
| <b>3-5 ADJUST THE DIOPTER</b> .....                               | <b>7</b>  |
| <b>3-6 ADJUST THE INTERPUPILLARY DISTANCE</b> .....               | <b>7</b>  |
| <b>3-7 ADJUST THE APERTURE DIAPHRAGM AND CONDENSER</b> .....      | <b>8</b>  |
| <b>3-8 USE THE OIL OBJECTIVE (100X)</b> .....                     | <b>8</b>  |
| <b>3-9 USE THE COLOR FILTER</b> .....                             | <b>9</b>  |
| <b>3-10 REPLACE THE FUSE (BUILT-IN SWITCH POWER SUPPLY)</b> ..... | <b>9</b>  |
| <b>3-11 USE THE USB DIGITAL HEAD</b> .....                        | <b>9</b>  |
| <b>3-12 USE THE HDMI DIGITAL HEAD</b> .....                       | <b>10</b> |
| <b>3-13 ASSEMBLE AND USE THE TV DEVICE</b> .....                  | <b>10</b> |
| <b>3-14 USE THE STAGE FOR BIOLOGICAL OBSERVATION</b> .....        | <b>10</b> |
| <b>3-15 USE THE CULTURE DISH FOR LIVING CREATURE</b> .....        | <b>12</b> |
| <b>3-16 USE THE PLATE FOR STEREO OBSERVATION</b> .....            | <b>12</b> |
| <b>4. TROUBLESHOOTING</b> .....                                   | <b>12</b> |

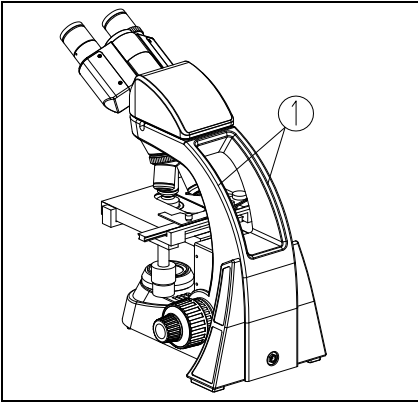
**1. Operation Notice**

Fig.1

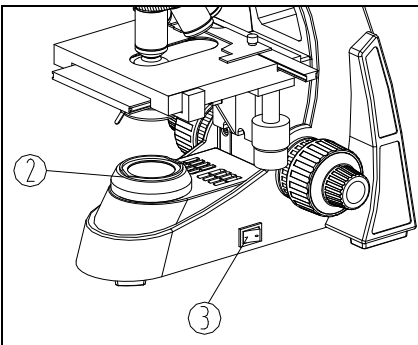


Fig.2

1. As the microscope is a high precision instrument, always operate it with care, and avoid physical shake during the operation.

2. Do not expose the microscope in the sun directly, either not in the high temperature, damp, dust or acute shake. Make sure the worktable is flat and horizontal. Following environment is required when operating: Indoor temperature: 5°C~40°C, Max relative humidity: 80%.

3. When moving the microscope, use both hands to hold its arm (1), and lay it down carefully (see Fig. 1).

★ It will damage the microscope by holding the stage, focusing knob or head when moving.

4. When working, the surface of light collector(also called illuminator) will be very hot. Make sure there is enough room for the heat dissipating around the light collector(also called illuminator) (2) (see Fig. 2).

5. For safety, make sure the power switch is at "O" (OFF) and power it off before replacing the bulb or fuse (See Fig. 2), and wait until both the bulb and bulb holder have cooled down.

6. Standard bulb: Single 3W LED bulb.

7. All the power OFF devices have been set in the position where is easy to operate.

8. No contraindications for this product.

## **2. Maintenance**

1. Wipe the lens gently with a soft tissue. Carefully wipe off the oil marks and fingerprints on the lens surfaces with a tissue moistened with a small amount of 3:7 mixture of alcohol and ether or dimethylbenzene.

**★ As the alcohol and ether is flammable, don't place these chemical near to fire or fire source. For example, when turning on or turning off the electrical device, please use these chemicals in a ventilated place.**


2. Don't use organic solution to wipe the surfaces of the other components. Please use the neutral detergent if necessary.

3. If the microscope is damped by liquid when using, please power it off immediately and wipe it dry.

4. Never disassemble the microscope, otherwise the performance will be affected or the instrument will be damaged.

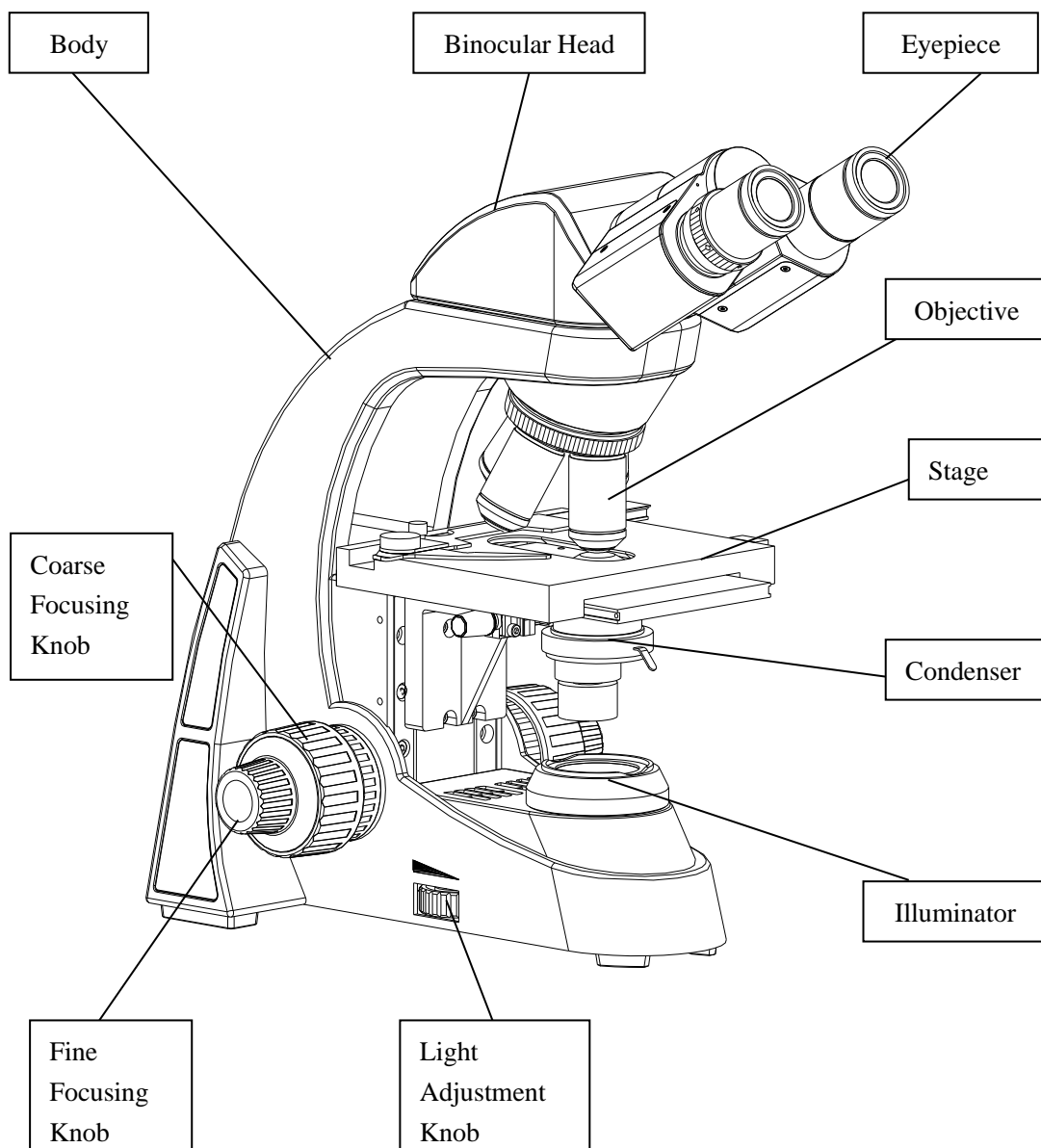
5. After using, cover the microscope with a dust cover.

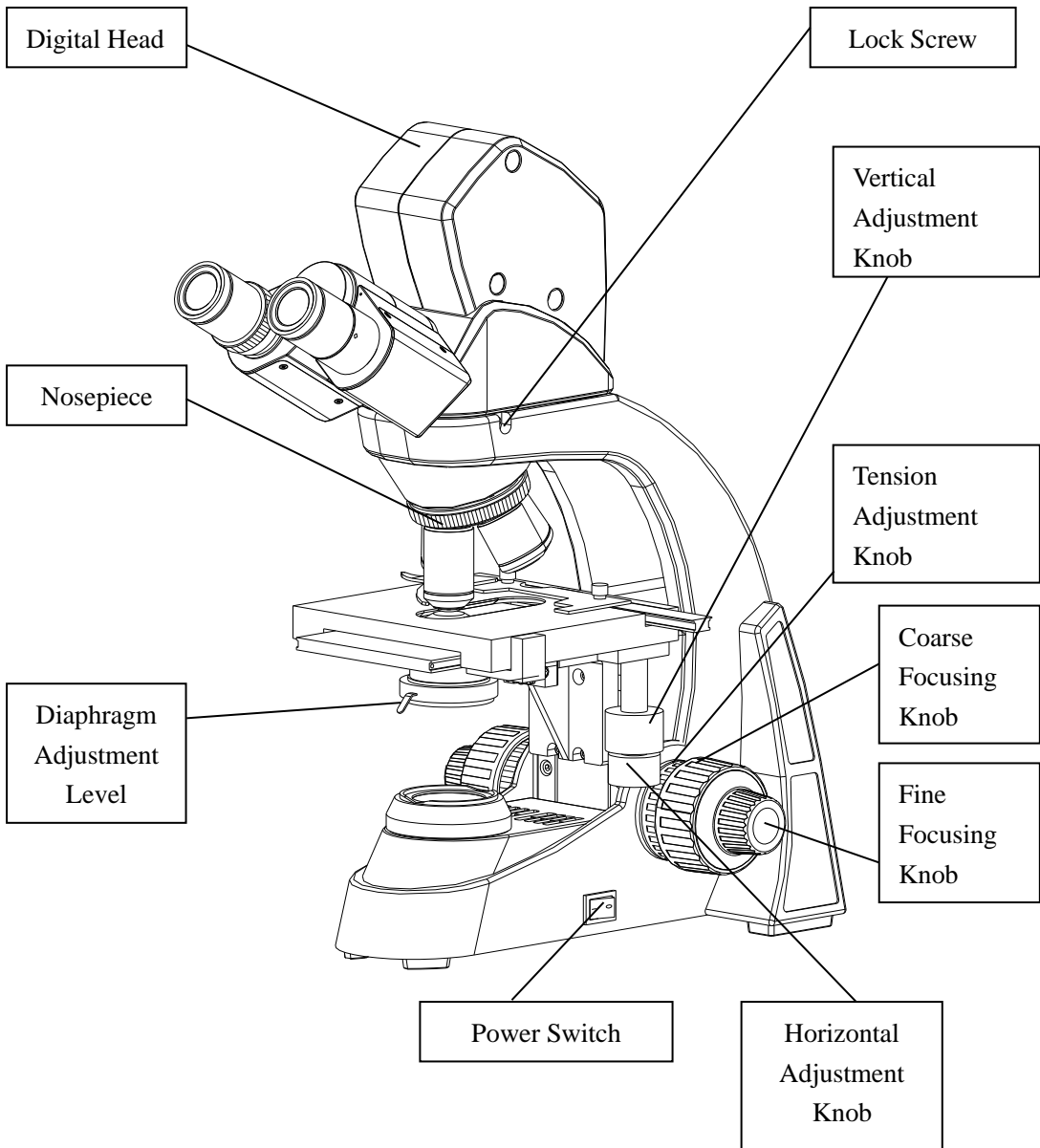
## **3. Safety Sign**

| Sign   | Signification   |
|--|---|
|  | Study the instructions before use. Unsuitable operation would lead to person hurt or instrument faulty. |
| I  | Main switch ON  |
| O  | Main switch OFF   |

1. Components

BS-2027 Series





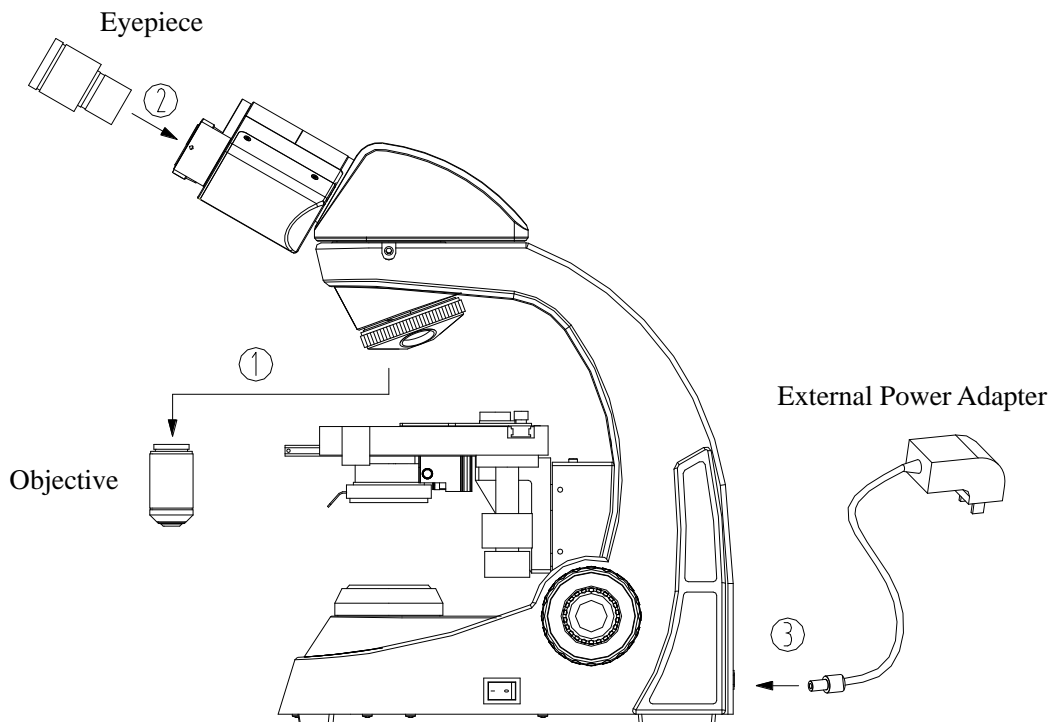
## 2. Assembling

BS-2027 Series

### 2-1 Assembling Scheme

Following is the Assembling Scheme, and the numbers denote the assembling order.

★ Before assembling, make sure there is no dust or dirt. Assemble carefully and do not scrap any part or touch the glass surface.



## 2-2 Assembling Steps

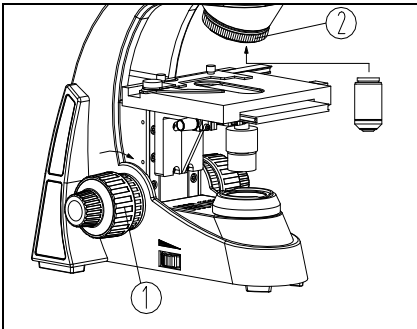


Fig.3

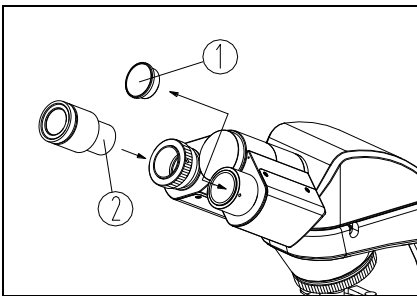


Fig.4

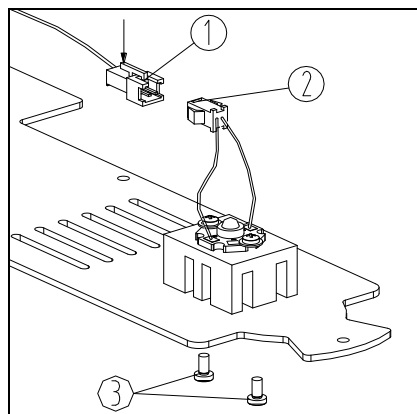


Fig.5

### 2-2-1 Assemble the Objective

1. Rotate the coarse focusing knob (1) to lower the stage to a suitable location (See Fig.3).
2. Install the objectives into the nosepiece from the lowest magnification to the highest in a clockwise direction.

★ Search and focus the sample by low magnification objective (4X or 10X) when operating. Then get change to the high magnification ones according to the observation requirements.

★ When replacing the objective, rotate the nosepiece until it sounds “click”, to make sure the objective is in the center of the light path.

### 2-2-2 Assemble the Eyepiece

1. Take down the cover of eyepiece tube (1).
2. Insert the eyepiece (2) into the eyepiece tube, until touch the bottom (See Fig. 4).

### 2-2-3 Assemble or Replace the LED

Screw out the lock screw on the bottom group and take out the bottom group. Press on snaps on the connector socket (1) (connected with LED control panel) according to the direction of the arrow as shown in the figure, pull out the connector (2) (connected with LED). Then screw out the two screws (3) that fixed the LED, replace with a new LED group. Fix the LED group by the two screws, plug the connector (2) into connector socket (1), assemble the bottom group to original place (See Fig.5).

★ Before replacing the LED, make sure to cut off the main power and wait for LED group cooling down, to avoid overheating and burns.



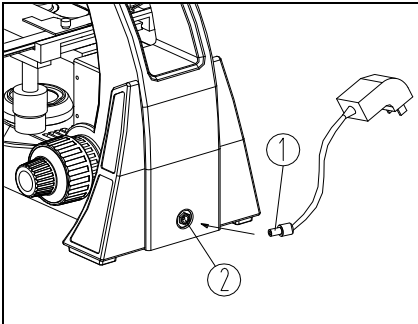


Fig.6

**2-2-4 Connect the External Power Adapter (Power Cord/Charger)**

- ★ Don't use strong force when the power cord is bended or twisted, otherwise it will be damaged.
- ★ Use the special external power adapter (power cord/charger) supplied by our company. If it's lost or damaged, choose one with the same specifications.

◎ **For External Power Adapter**

1. Make sure the power switch is at "O" (OFF).
2. Insert one end of external power adapter ① into the power socket ② of the microscope. Then insert the other end into the power supply socket and make sure well-connected (See Fig. 6).

★ **Adopt DC6V 2A external power supply. Make sure use an external power adapter complies with this requirement.**

★ **The models with rechargeable battery must use DC6V 1A external battery charger for charging. When instrument is fully charged, the charger indicator will change from orange to green. When replacing rechargeable battery, use high-quality 5 # rechargeable battery.**

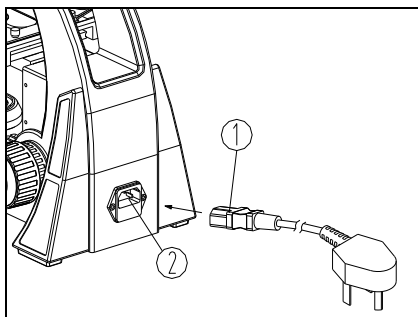


Fig.7

◎ **For Built-in Switch Power Supply**

1. Make sure the power switch is at "O" (OFF).
2. Insert one end of power cord ① into the power socket ② of the microscope. Then insert the other end into the power supply socket and make sure well-connected (See Fig.7).

★ **The power supply box supports wide voltage as 100-240V. No additional external power adapter is needed.**

★ **Connect the power cord appropriately to make sure the instrument is connected to ground.**

**3. Operation**

*BS-2027 Series*

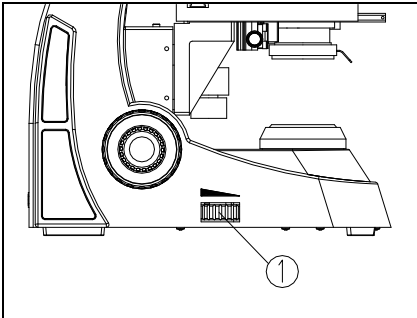


Fig.8

**3-1 Set Illumination**

1. Put through the power and turn on the main power switch to “—”(ON).
2. Adjust the light adjustment knob ① until the illumination is comfortable for observation. Rotate the light adjustment knob clockwise to raise the voltage and brightness. Rotate the light adjustment knob counterclockwise to lower the voltage and brightness (see Fig. 8).

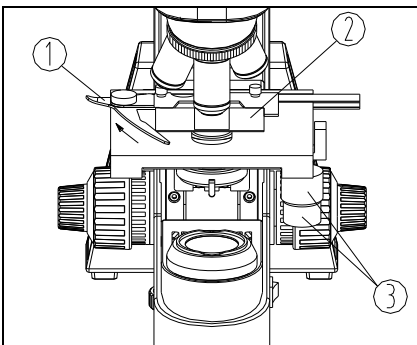


Fig.9

**3-2 Place the Specimen Slide**

1. Push the wrench of the specimen holder backwards.
2. Loosen the wrench ①, and clamp the slide ② by the clips while the cover glass faces up (see Fig. 9).
3. Rotate the X and Y-axis knob ③. Move the specimen to the center (alignment with the center of the objective).

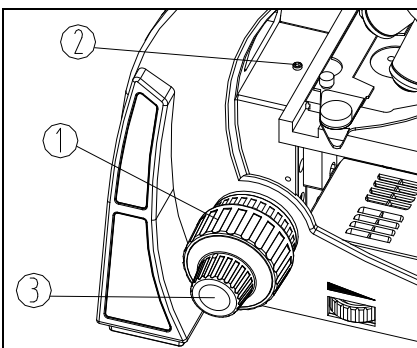


Fig.10

**3-3 Adjust Focusing**

1. Shift the 4X objective into the light path.
  2. Observe the right eyepiece with the right eye. Rotate the coarse focusing knob ① until the image outline appears in the view field (See Fig.10).
  3. Rotate the fine focusing knob ③ for clear details.
- ★The lock screw ② can prevent the objective touching the slice when focusing.

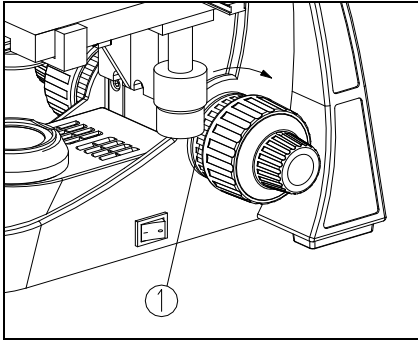


Fig.11

### 3-4 Adjust the Focusing Tension

If the handle is very heavy when focusing or the specimen leaves the focus plane after focusing, or the stage declines itself, rotate the tension adjustment knob ① to resolve the problem (See Fig. 11).

Rotate the tension adjustment knob ① according to the direction of the arrow as shown in the figure, to lock the focusing system. Rotate it to the opposite direction to loosen the focusing system.

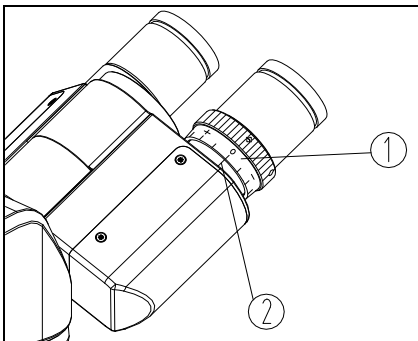


Fig.12

### 3-5 Adjust the Diopter

Observe the right eyepiece with the right eye, focus it until the image is clear. Then observe the left eyepiece with the left eye, if the image is not clear enough, rotate the diopter adjustment ring ① until the image is clear (See Fig.12).

★There are  $\pm 5$  diopters on the diopter adjustment ring ①, and the value aligned with the scale ② is your eye's diopter.

★When using diopter adjustable eyepiece, do eyepiece diopter zero adjustment first. Adjust eyepiece diopter to make the image clear when operating.

★Remember your diopter, you can use it next time.

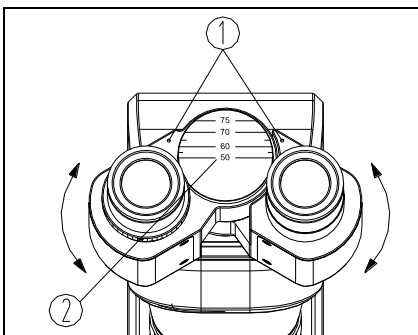


Fig.13

### 3-6 Adjust the Interpupillary Distance

When using two eyes to observe, hold the bases of the prism and rotate them around the axis to adjust the interpupillary distance, until there is only one field of view. The dot “.” ① on the eyepiece base points to the scale ② of the interpupillary distance indicator. The scale value is the interpupillary distance (See Fig. 13).

Adjustable range: 50~75mm.

★Remember your eye's interpupillary distance, so that you can use it next time.

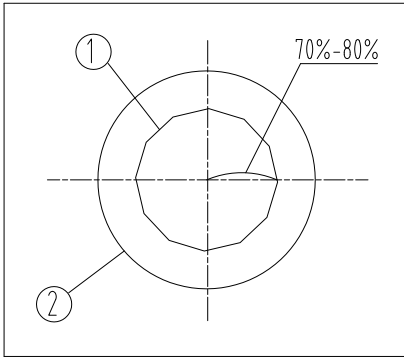


Fig.14

### 3-7 Adjust the Aperture Diaphragm and Condenser

1. The aperture diaphragm decides the numerical aperture of the illumination system. If the N.A. of illumination system matches with the N.A. of the objective, it can obtain better resolution and contrast, and increase the depth of field.

2. Adjust condenser adjustment knob ③ in clockwise direction, raise the condenser to the top, let the illumination light fills the field of view. As the specimen contrast is usually low, it is advised to adjust the condenser aperture diaphragm to be 70%-80% of the N.A. of objective. Rotate the aperture diaphragm adjusting ring ④, align the arrow with the magnification position on the diaphragm seat ⑤. The eyepiece can be taken off when it's necessary to observe from the tube. Adjust the aperture diaphragm adjusting ring ④ until see the figure as shown in Fig. 14, to adjust the proportion (see Fig. 14&15, ① is the image of aperture diaphragm, ② is the edge of objective).

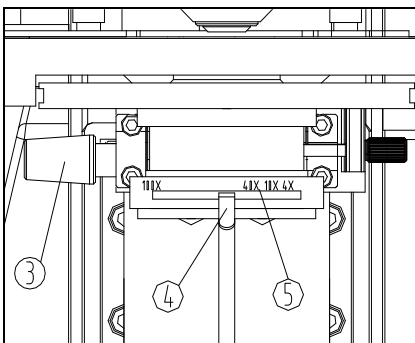


Fig.15

### 3-8 Use the Oil Objective (100X)

1. Use the 4X objective to focus the specimen.  
 2. Place a drop of oil ① on the specimen (see Fig. 16).  
 3. Rotate the nosepiece counterclockwise and rotate the oil objective (100X) to the light path. Then use the fine focusing knob to focus.

★ **Make sure there is no air bubble in the oil for fear affect the image.**

A. Move the eyepiece to examine the air bubble. Open the aperture diaphragm and field diaphragm fully and observe the edge of the objective from the tube (It seems round and light).

B. Rotate nosepiece slightly and swing the oil objective for some times to remove the air bubble.

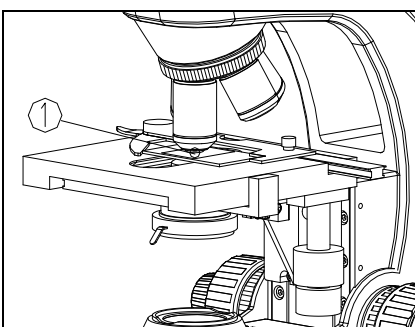
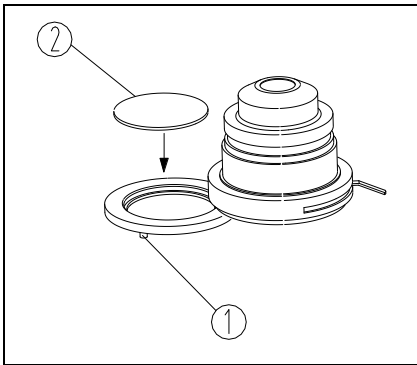


Fig.16

4. After using, wipe the front lens with a tissue moistened with a small amount of 3:7 mixture of alcohol and ether or with dimethylbenzene. Wipe off the oil on the specimen.

★ **Don't put another objective to the light path before the oil is wiped to avoid wetting the dry objective.**

★ **Too much dimethylbenzene would dissolve the lens's stickiness.**



### 3-9 Use the Color Filter

Screw out the color filter frame (1) at the bottom of the condenser in clockwise direction, press the filter (2) into its hole, then screw in the frame in counterclockwise direction (See Fig.17).

★ **There are three colors of filter selectable: blue, green and yellow.**

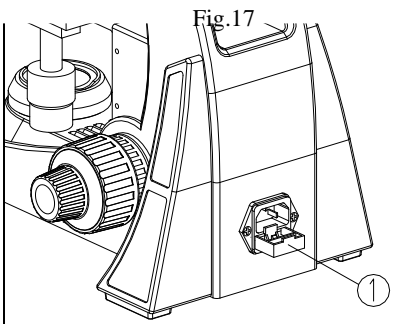


Fig.18

### 3-10 Replace the Fuse (Built-in Switch Power Supply)

Turn the main switch to "O" (OFF) before replacing the fuse. Pull out the power cord. Pull the fuse base (1) until the fuse can be take out from the fuse base. Install a new fuse and push it in the fuse base thoroughly (See Fig. 18).

### 3-11 Use the USB Digital Head

★ **Don't use strong force when the data cable is bended or twisted, otherwise it will be damaged.**

Insert the connector (1) of data cable into the USB interface (2) on the back of microscope head, and insert the other connector into the USB interface of the computer (See Fig.19), view microscope video by video capture and analysis software and use binocular observation (Only for USB digital microscope.)

Digital USB interface: voltage 5V, current  $\leq 500\text{mA}$ .

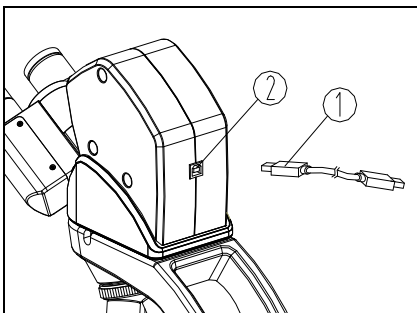


Fig.19

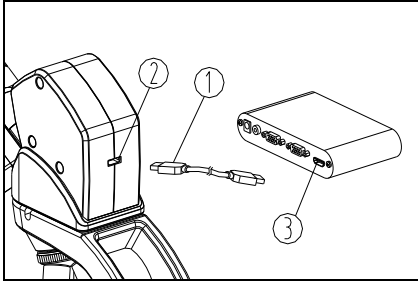


Fig.20

### 3-12 Use the HDMI Digital Head

★Don't use strong force when the data cable is bended or twisted, otherwise it will be damaged.

Insert the connector ① of HDMI cable into the HDMI interface ② on the back of microscope head, view the real time image by connecting the other end to the control and convert device ③ (See Fig.20) and use binocular observation (Only for HDMI digital microscope.)

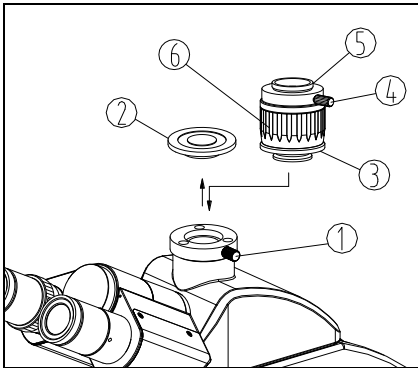


Fig.21

### 3-13 Assemble and Use the TV Device

1. Loosen the lock screw ① of trinocular head, and take out the dust-cover ② (See Fig.21).
2. Take down the dust-cover of the TV adapter ③. Insert the TV adapter into the trinocular head as shown in the figure and screw down the lock screw ①.
3. Loosen the lock screw ④ of the TV adapter. Take down the vidicon interface (C type) ⑤ from the TV adapter, and screw into the CCD or vidicon. Then install the interface into the TV adapter, and screw down the lock screw ④.
4. For binocular observation, observe CCD image when the image is clear. If the image is unclear, rotate the adjustment tube ⑥ until it is clear.

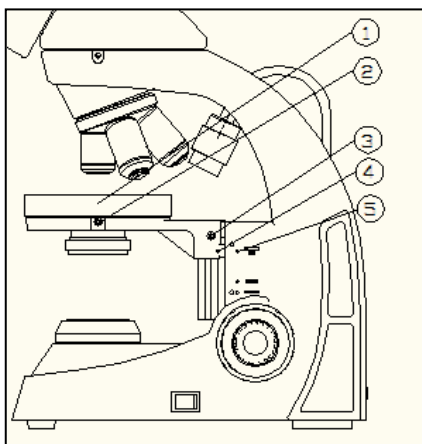


Fig 22

### 3-14 Use the Stage for Biological Observation

Put the round stage ① into the holder, use a hexagonal wrench lock the screw ②. Adjust coarse focusing wheel to lift the holder to the top position, loose the screw ③ to move the holder, and then lock the screw ③ when the mark ④ and ⑤ are horizontally aligned. (See Fig.22)

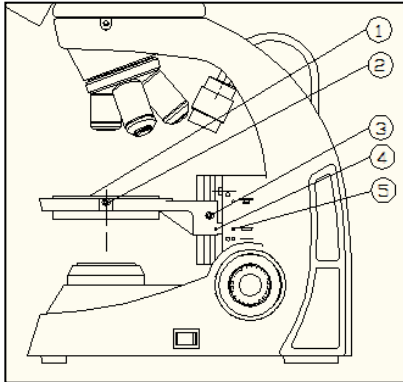


Fig 23

**3-15 Use the Culture Dish for Living Creature**

Put the culture dish ① into the holder, use a hexagonal wrench lock the screw ②. Adjust coarse focusing wheel to lift the holder to the top position, loose the screw ③ to move the holder, and then lock the screw ③ when the mark ④ and ⑤ are horizontally aligned. (See Fig.23) (Only available under 2X objective)

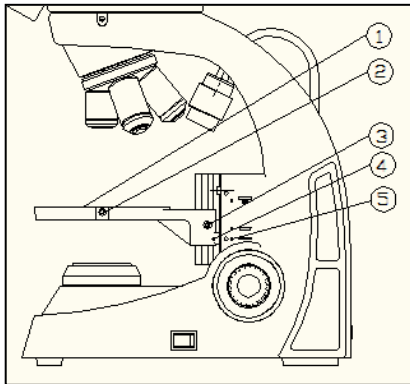


Fig 24

**3-16 Use the plate for Stereo Observation**

Put the plate ① into the holder use a hexagonal wrench lock the screw ②. Adjust coarse focusing wheel to lift the holder to the top position, loose the screw ③ to move the holder, and then lock the screw ③ when the mark ④ and ⑤ are horizontally aligned. (See Fig.24) (Only available under 2X objective)

**4. Troubleshooting**
*BS-2027 Series*

As the performance of microscope can't play fully due to unfamiliar operations, the table below can provide some solutions.

| <b>Problem</b>   | <b>Cause</b>   | <b>Solution</b>                                      |
|--|--|--|
| <b>1. Optical system</b>   |  |  |
| (1) The bulb is bright but it is dark in the field of view.                              | Field diaphragm is not large enough.   | Enlarge the field diaphragm.                         |
|  | Condenser is too low.  | Adjust the condenser.                                |
| (2) The side of the field of view is dark or not even.                                   | The nosepiece is not in the right position.                                    | Turn the nosepiece into the right position.          |
|  | Stain or dust has accumulated on the lens (condenser, objective or eyepieces). | Clean the lens.                                      |
| (3) Stain or dust is observed in the field of view.                                      | Stains have accumulated on the specimen.                                       | Clean the specimen.                                  |
|  | Stains have accumulated on the lens.   | Clean the lens.                                      |
| (4) Unclear image  | No cover glass on the specimen slide.  | Add the cover glass.                                 |
|  | The cover glass is not standard.   | Use a standard cover glass with thickness of 0.17mm. |
|  | The specimen faces down.   | Put the specimen to face up.                         |
|  | The immersion oil has accumulated on the dry objective.                        | Clean thoroughly.                                    |
|  | The immersion oil is not used for oil objective.                               | Use immersion oil.                                   |
|  | Air bubble in the immersion.   | Get rid of the air bubble.                           |
|  | Use wrong immersion oil.   | Use a correct one. (Cedar oil)                       |
|  | The aperture diaphragm is not opened correctly.                                | Adjust it.   |
|  | Stain or dust has accumulated on the lens of eyepiece.                         | Clean the lens.                                      |
| (5) One side of the image is dark or the image moves while focusing.                     | Condenser is too low.  | Adjust the condenser.                                |
|  | The specimen slide is not fixed.   | Fix it with clips.                                   |
|  | The nosepiece is not in the right position.                                    | Turn the nosepiece into the right position.          |
| (6) The eyes feel tired easily. The right field of view doesn't superpose with the left. | Condenser is not centered.   | Center the condenser.                                |
|  | Interpupillary distance is incorrect.  | Adjust the interpupillary distance.                  |
|  | The eyepiece for the right eye is different from the left one.                 | Use the same eyepieces.                              |



| <b>Problem</b>   | <b>Cause</b>                                       | <b>Solution</b>   |
|--|--|---|
| <b>2. Mechanical system</b>  |  |   |
| (1) Cannot focus when using high magnification objective.              | The cover glass faces down.                        | Put the cover glass to face up.                             |
|  | The cover glass is too thick.                      | Use a standard cover glass with thickness 0.17mm.           |
| (2) The objective touches the cover glass while turning the nosepiece. | The cover glass faces down.                        | Put the cover glass to face up.                             |
|  | The cover glass is too thick.                      | Use a standard cover glass with thickness $\delta 0.17$ mm. |
| (3) Coarse focusing knob is too tight.                                 | Tension adjustment knob is too tight.              | Loosen it to an appropriate position.                       |
| (4) Stage declines itself and cannot stay on the focal plane.          | Tension adjustment knob is too loose.              | Tighten it to an appropriate position.                      |
| (5) Coarse focusing knob cannot rise.                                  | The coarse focusing limit knob is locked.          | Loosen the coarse focusing limit knob.                      |
| (6) Coarse focusing knob can't decline.                                | The base of the condenser is too low.              | Raise the base.   |
| (7) Cannot move the slide smoothly.                                    | The slide is not fixed correctly.                  | Adjust it correctly.  |
|  | The movable specimen holder is not fixed properly. | Adjust it correctly.  |
| (8) The image moves obviously when touching the stage.                 | The stage is fastened incorrectly.                 | Fasten the stage correctly.                                 |
| <b>3. Electrical Part</b>  |  |   |
| (1) The bulb does not work.  | No power supply.                                   | Check the connection of the power cable.                    |
|  | The bulb is not installed correctly.               | Install it correctly.                                       |
|  | The bulb burns out.                                | Replace it.   |
| (2) The bulb burnt out usually   | A wrong bulb is used.                              | Replace it with a correct one.                              |
| (3) The field of view is not bright enough                             | A wrong bulb is used.                              | Replace it with a correct one.                              |
|  | The use of light adjusting knob is incorrect.      | Adjust it correctly.  |