

LED Fluorescent Biological Microscope

BS-2070FB(LED)/FT(LED)

User Manual

This manual is for LED fluorescent biological microscope Model BS-2070FB(LED)/FT(LED). To ensure the safety, obtain optimum performance and to familiarize yourself fully with the use of this microscope, it is strongly recommended that you study this manual thoroughly before operating the microscope.

Content

User Notice.....	2
1. Safety Note.....	2
2. Maintenance and Care.....	2
LED Fluorescent Part.....	3
1. Components Name.....	3
2. Installation.....	4
3. Adjustment and Operation.....	5
4. Configuration and Specifications.....	6
Microscope Part.....	7
1. Components Name.....	错误！未定义书签。
2. Assembly.....	错误！未定义书签。
3. Adjustment and operation.....	错误！未定义书签。
4. Technical Specifications.....	错误！未定义书签。
5. Outfit.....	错误！未定义书签。
6. Troubleshooting Guide.....	错误！未定义书签。

User Notice

1. Safety Note

1. Open the box carefully to avoid the accessories, like lens, dropping to ground or being damaged.
2. Do keep the instrument out of direct sunlight, high temperature or humidity, dusty and easy shaking environment. Make sure the stage is flat, horizontal and firm enough.
3. When moving the microscope, carefully carry it with the handle and the base.
4. When running, the lamp house and nearby parts will be very hot. Please ensure there is enough cooling room for them.
5. Make sure the instrument is earthed, to avoid lightning strike.
6. For safety, be sure the main switch is in “O”(off) state and cut off the power supply before replacing the bulb or the fuse. If you replace the bulb during use or right after use, allow the lamp bulb and the lamp house to cool completely before touching.
(Designated bulb: 6V/20W Halogen Lamp)
7. Check the input voltage: be sure the input voltage which is signed in the back of the microscope is consistent with the power supply voltage, or it will bring a serious damage to the instrument.
8. Always use the power cord provided by BestScope.

2. Maintenance and Care

1. All the lenses have been adjusted properly; do not dismount them by yourself please.
2. The nosepiece and coarse and fine focusing parts are so delicate that it is forbidden to disassemble them carelessly by yourself.
3. Keep the instrument clean, and do not pollute the optical element when wiping away the dust on the instrument.
4. The contaminations on the prism, like fingerprints and oil smudges, could be gently wiped with a piece of soft cloth or tissue paper, gauze which has been immersed in pure alcohol or ether.
(Note that the alcohol and ether are highly flammable, do keep them away from the fire or potential sources of electrical sparks, and use them in a drafty room as possible as you can.)
5. Do not attempt to use organic solvents to clean the microscope components other than the glass components. To clean them, use a lint-free, soft cloth slightly moistened with a diluted neutral detergent.
6. When using, if the microscope is splashed by liquid, cut off the power at once, and wipe away the splash.
7. Do not disassemble any parts of the microscope, as this will affect the function or reduce the performance of the microscope.
8. Place the instrument in a cool, dry position. When not using the microscope, keep it covered with a dust cover. Make sure the lamp socket is cool before covering the microscope.

LED Fluorescent Part

This fluorescent attachment is designed for infinite optical system.

1. Components Name

FL-LED fluorescent attachment: (Fig.1)

- ① Brightness adjustment knob
- ② Condenser focusing knob
- ③ Main body of fluorescent attachment
- ④ Filter subassembly
- ⑤ Fastening bolt
- ⑥ Fluorescent objective
- ⑦ Light barrier control lever
- ⑧ Power adapter

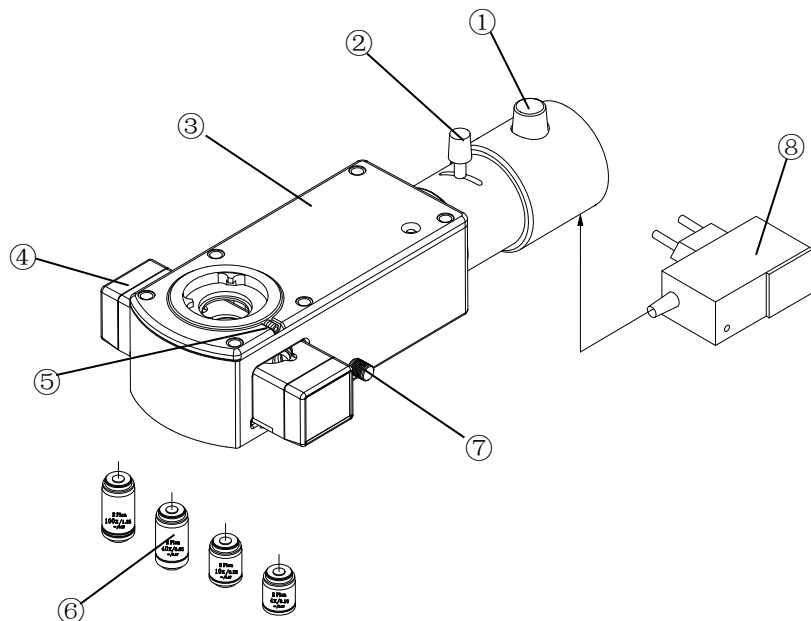

Fig.2

Electrical parameters:

External electric supply: 110V-240V 50/60 Hz

Input Voltage: DC7.5V 1000mA

Fluorescent illuminator: LED 3W (Blue)

2. Installation

For installation instruction, take BS-2040FB(LED) fluorescent biological microscope for example:

- BS-2070FB(LED) LED Fluorescent Microscope=biological microscope BS-2070B+FL-LED attachment

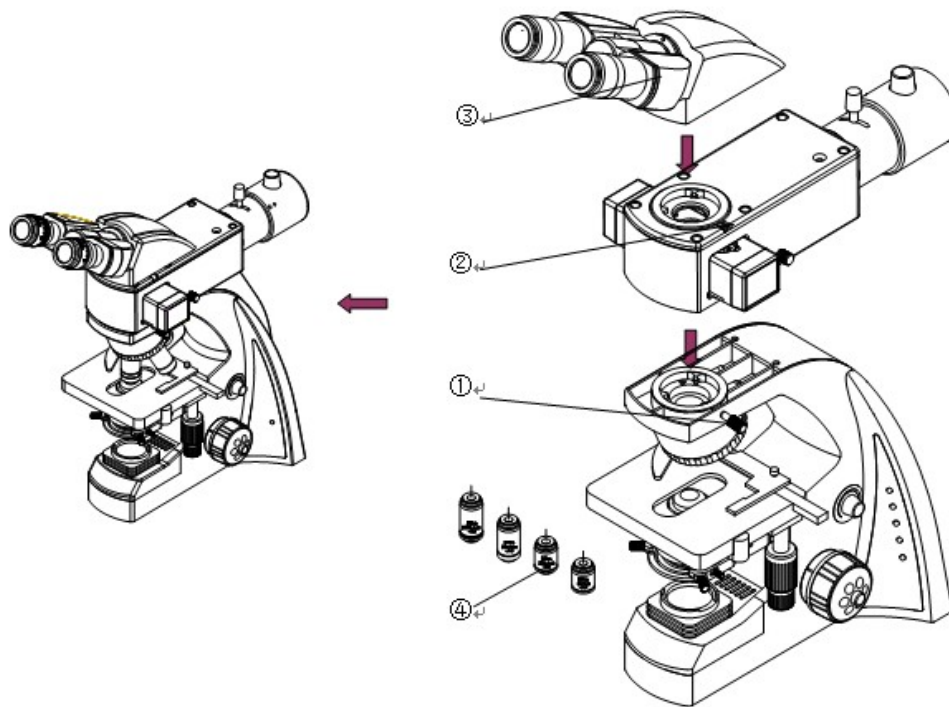

Fig. 3

Fluorescent Microscope Assembly:

- 1) Loosen the clamping screw ① on biological microscope BS-2070B and remove the binocular viewing head from the body of microscope by revolving it counterclockwise by 90° .
- 2) Insert the main body of fluorescent attachment into the upper part of the microscope BS-2070B ,adjust the orientation and tighten the clamping screw ①.
- 3) Insert the binocular viewing head into the main body of the fluorescent attachment, adjust its orientation and tight the clamping screw ② to fix the head.
- 4) Replace the original biological objective with special fluorescent objectives ④.

NOTE:

1. Both top and bottom illumination system can be used for fluorescent microscope. But for this fluorescent attachment, only top illuminator can be used while bottom illuminator is closed. The filter subassembly is set at the middle position (B excitation state); For normal biological observation, use bottom illuminator while top illumination is closed. The filter subassembly is set at empty position.
2. It is necessary to adjust biological microscope system firstly before

3. Adjustment and Operation

3.1 Fluorescent Operation System

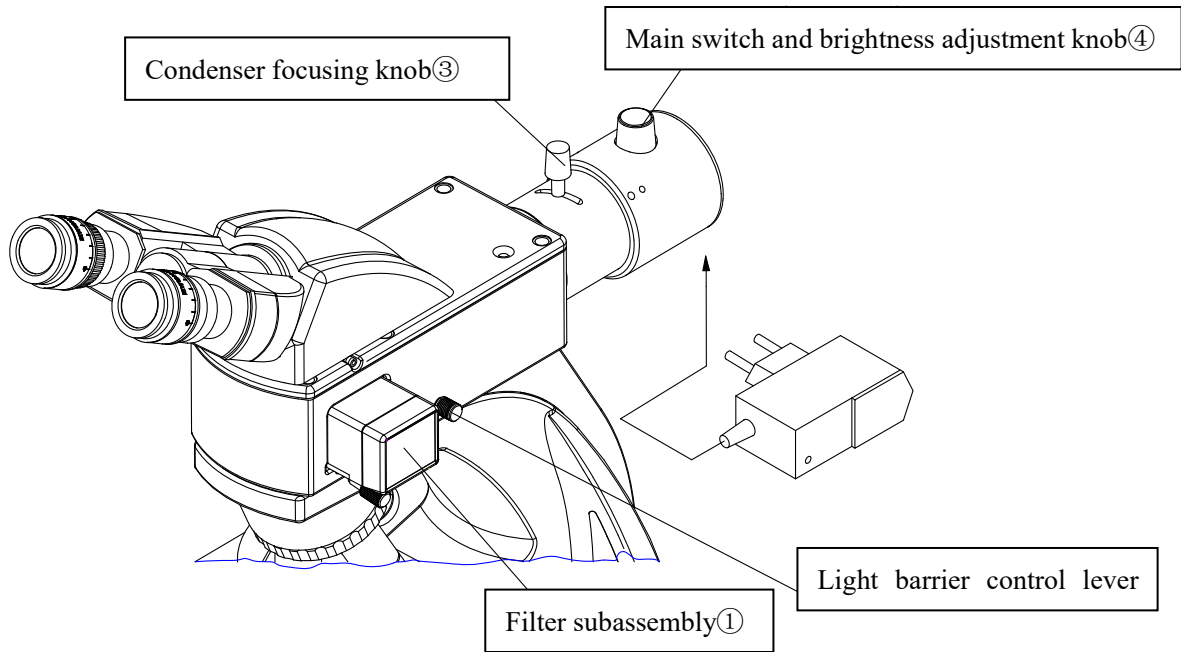

Fig.4

3.2 Fluorescent Microscope Operation (Fig.4, Fig.5)

1. Set the filter subassembly① at the middle position to engage B excitation filter into the light path.
2. Connect the power supply onto the microscope, turn on the main switch and adjust brightness adjustment knob④ to a proper intensity.
3. Adjust the condenser focusing knob③ to make the field of view full.
4. Place the specimen on the stage for observation and operation.
5. During observation, use the light barrier lever② to obscure the light path so that the main switch is not open and closed frequently.

● The standard FL-LED fluorescent attachment are equipped with b-excitation filter (in the middle position). If you need other types of filters, please purchase separately.

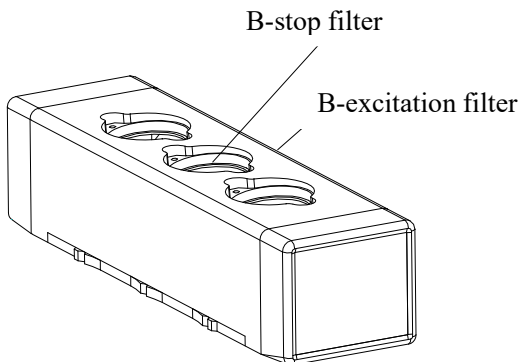

Fig.5

3.3 Precautions for Operation

1. Check that the power voltage and frequency is consistent with the product requirements.
2. Ensure that the plug is inserted fully and well connected.
3. If only for transmitted light observation (biological microscopy), pull out the filter subassembly or push inward it to engage the empty position into the optical path.
4. When Using the oil immersion objective (100x), be sure to use specified immersion oil for fluorescent observation.
5. If you interrupt observation within a short time, use the light barrier to block light.

4. Configuration and Specifications

Components Name	Specifications	Outfit
Fluorescence main body		●
Infinite plan fluorescence objective	4×, 10×, 40×, 100×	○
Filter subassembly	B excitation	●
Filter subassembly	G excitation	○
Illuminator	3W LED Lamp (465-475nm blue)	● (with B excitation)
	3W LED Lamp (520-530nm green)	○ (with G excitation)
Adapter	DC7.5V 1000mA	●

NOTE: “●” Standard outfit ; “○” Optional

Microscope Part

Safety notice

1. Transportation

As microscope is a precision instrument, handle with care, avoiding impact or abrupt movement during transportation. Do not push or pull the microscope during using, otherwise the precision for image will be reduced.

1.1 Hold the curve and keep the microscope in balance

1.2 Do not hold the focusing knob, eyepiece tubes and stage as these parts are movable. Troubles maybe caused by such handles.

Do not make specimen or filters fall off.



2. Working Environment

As microscope is a precision instrument, improper using will make it unworkable or reduce its precision.

2.1 Do not expose the microscope in the sun directly

2.2 Temperature range is 0°C ~40°C and the max. humidity is 85%

2.3 Avoid high temperature and humidification otherwise there will be fog or mold on the lens

2.4 Avoid violent vibration as the vibration will reduce the image's quality

2.5 Place microscope on a stable plane and keep it in balance. Keep the environment breezy and cover the microscope with the dust-cover

2.6 Do not place microscope in moist room to avoid short circuit. Please turn off the power supply as soon as water drop in the microscope. If there are other things unsafe come into the microscope may cause short circuit too, please stop using and contact with manufacturers

3. Focusing knob

Never turn the left and right focusing knob in the adverse direction at the same time. Do not turn the coarse focusing knob when the stage reaches max. position. These improper operations will make focusing structure unworkable.



4. Clamp

The clamps fix the microscope firmly during transportation. Please remove them before using.



5. Do not take the microscope apart as it will be damaged. Such operations might have bad effect on the performance and make user get an electric shock or injured. Please contact with manufacturers if there is any problem.

6. There is correct input voltage in the label on microscope.

Make sure the voltage in your position is right. Improper input voltage may cause short circuit and fire. The microscope will be damaged.

Input voltage in the label: 220~240V 50/60Hz

Working voltage could be AC 220V, 230V or 240V



7. The bulb, fuse and electronic cord have been assembled already in the factory and please make sure to use the spare parts of them supplied by the manufacturers. Improper bulb, fuse and electronic cord will destroy microscope and cause fire. Please make sure to use PE electronic cord when using extra-long electronic cord.

Spare bulbs: halogen bulb 12V20W (or 12V30W)

Spare fuse: 250V 1A delayed model, 5 × 20 minitype fuse

8. Never touch the surface of bulb with your hand directly. Please use gloves or cloth material when you mount the bulb to avoid leaving fingerprints. Fingerprints or stains should be wiped off with a tissue moistened with a small amount of alcohol. The fingerprints will etch on the bulb's surface and make brightness lower and life cycle shorter.

Please make sure the bulb's touching points are Ok as it will not light or short circuit if the bulb's touching points are damaged. Insert the bulb's legs into the bulb holder firmly. The bulb will go out if its legs have not been inserted into the holder firmly. Such Operation may cause short circuit or smoking. At last, please make sure if the collector has been mounted properly

9. Temperature for illumination

There will be high temperature when the bulb is lightened, never move the collector when the bulb is lightened. Do not touch the bulb within 30 minutes after it has been gout out. Make sure the bulb has been be cooling enough time (at least 30 minutes) to avoid scald.

Do not put fibre, papers and incendive things (eg. Gasoline, aether, methanol and ethanol) close to the bulb.

10. Make sure to turn off the power supply before assembling microscope, replacing bulb or fuse.

11. Using small amount of oil immersion is enough. The redundant oil will adhere to stage or condenser and these will reduce microscope's performance.

Get rid of the redundant oil or clean the lens by using aether or pure alcohol according to this instruction. Pay attention during process as these things are incentive

The instruction you buy may not including some products mentioned in this instruction. Safety has been considered during design while users still have the possibility to be injured and the instruction to be damaged when improper operation made. Please pay much more attention to read this instruction carefully before using and keep it properly to make sure it will be got when it is necessary.

1. Structure and nomenclature

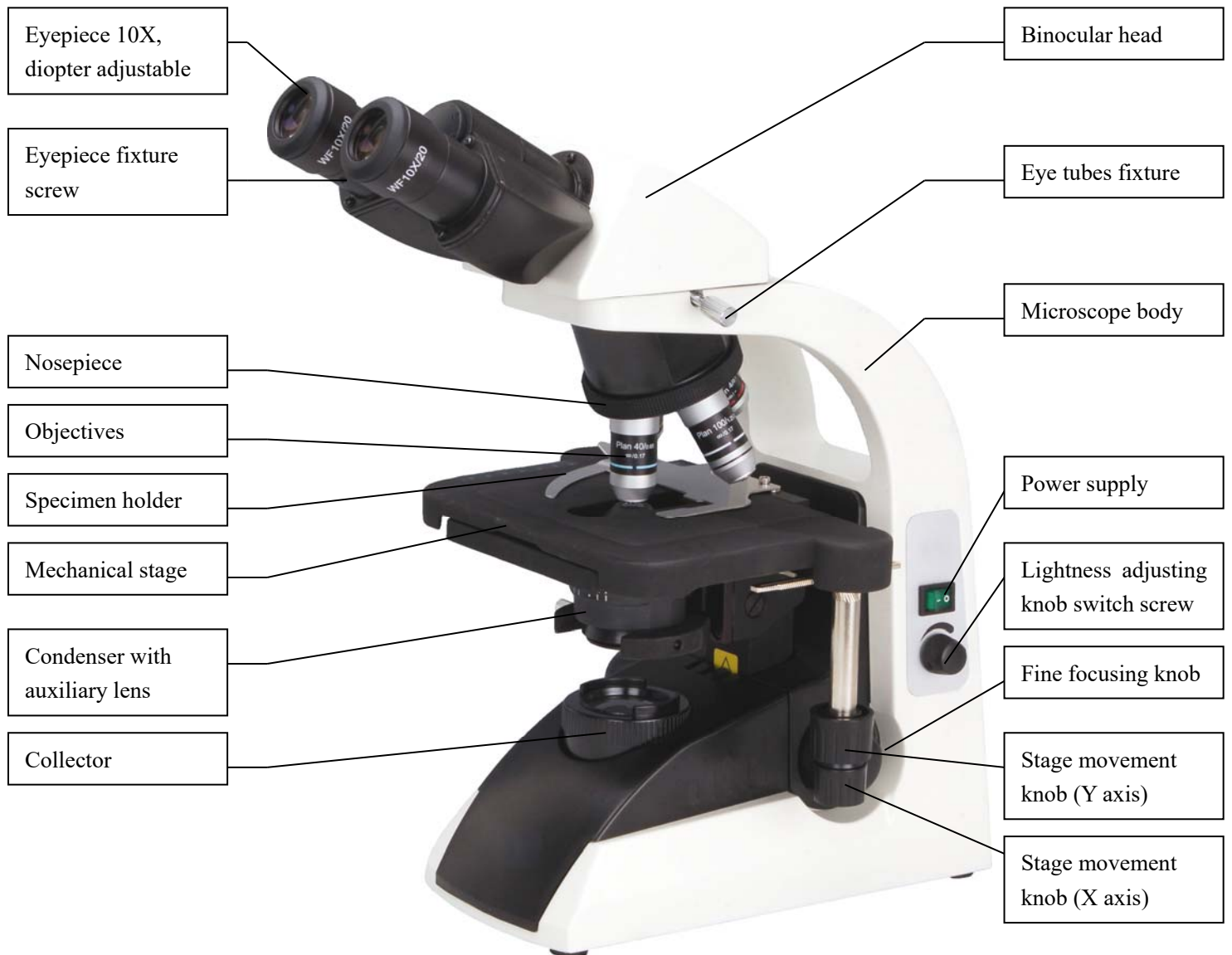

2. Technical parameter and specification

1. Specification

1.1 Optical system: infinity optical system

1.2 Illumination: inserted transmitted illumination, 12V20W/30W halogen bulb (standard outfit) or LED (available)

Input voltage: 220V~240V 50/60Hz

Voltage undulation: $\pm 10\%$

Electric current: 0.4A

Fuse: 250V 1A delayed model, 5×20 minitype fuse 2pcs

1.3 Focusing adjustment: Division of fine focusing adjustment: 0.002mm

Fine focusing knob control range: stage will be up or down 0.2mm per circle

Coarse focusing knob control range: stage will be up or down 20mm

1.4 Mechanical stage: X-movement range: 54mm, Y-movement range: 78mm

1.5 Nosepiece: Roller bear quadruple nosepiece

1.6 Condenser: Abbe NA=1.25 with iris diaphragm

1.7 Eye tubes: Interpupillary range 55~75mm

1.8 Working environment: Temperature: 0°C~40°C

Humidity: max. 85%, no dew

Altitude: within 2000m

Pollution: 2

Assembly: II

2. Optical parameter

2.1 Objectives: Infinite plan achromatic objectives

Magnification	N.A.	Cover glass thickness(mm)	W.D. (mm)	Dry/Oil
4X	0.1	0.17	15.5	Dry
10X	0.25	0.17	5.02	Dry
40X	0.65	0.17	0.6	Dry
100X	1.25	0.17	0.13	Oil

2.2 Eyepiece: WF10X/20mm

Nomenclature

* Total magnification

Total magnification = Eyepiece's magnification × objective's magnification

* Numerical aperture (N.A.)

N.A. value will affect resolution and image's brightness, it is the leading parameter for objectives. $N.A. = n \times \sin \alpha$

n stands for refractive index of the medium between objective and specimen or condenser (air or oil immersion)

α stands for half angle of max. aperture angle in the axis

The image will be sharper and brighter when the N.A. value is bigger

* Resolution

Resolution can be measured by the distance value from one point to another one which could be distinguished on the object surface

Resolution = $\lambda / (2 \times \text{N.A.})$

λ stands for wavelength ($\lambda = 0.55\mu\text{mm}$)

* Eyepiece view field

The max diameter measured when the diaphragm is open. 10X/20 means the magnification is 10X and the max diameter of view field is 20mm

* Effective view field

Liner view field which is observed on the object surface

Effective view field = eyepiece view field / objective's magnification

* Depth of field

Depth of field stands for depth of the space in which there is sharp image on the object surface. Depth of field will be longer when the diaphragm reduces. Depth of field will be shorter when the N.A. becomes bigger.

3. Configuration

Item	Content	Piece	
1	Microscope's body (including stage, nosepiece, coaxial coarse and fine focusing adjustment, bracket for condenser, adjusting power supply, halogen bulb and normal collector)	1 pc	
2	Siedentopf binocular inclined at 30° (360° rotatable)	1 pc	
3	Condenser (with iris diaphragm, without auxiliary lens)	1 pc	
4	Objectives (Infinity achromatic objectives)	4X	1 set
		10X	
		40X	
		100X	
5	WF10X eyepiece	2 pcs	
6	Blue filter	1 set	
7	Electronic cord	1 pc	
8	Immersion oil	1 bottle	
9	Dust cover	1 pc	
10	Instruction and quality certificate	1 pc	
11	Halogen bulb (12V20W)	2 pcs	
12	Wrench 2.5, 1.5	1 pc	

Optional

Item	Contents	Piece	
1	Collector with diaphragm		
2	Condenser (with iris diaphragm and auxiliary lens)		
3	Dark field condenser		
4	WF10X eyepiece with reticle		
5	WF15X eyepiece (15mm)		
6	Objectives (Infinity plan objectives)	4X	
		10X	
		40X	
		100X	
7	60X/0.85 achromatic objective		

8	LED transmitted illumination	
9	Siedentopf trinocular inclined at 30° (360° rotatable)	

4. Assemblage

Please read the safety notice carefully before assembly and make the assembly according to the following steps.

Tools: wrench (2 pcs)

4.1 There is correct input voltage in the label on microscope. Make sure the voltage in your position is right. Improper input voltage may cause short circuit and fire. The microscope will be damaged.

Turn off the power supply (turn the switch to “O”) and insert one end of the electronic cord (connector) into the entrance for AC. Insert the other end of the electronic cord (pin) into the grounded AC connector and make sure that the electronic cord has been connected safely

- * Please use the supplied electronic cord by manufacturer
- * Please make sure to use PE electronic cord when using extra-long electronic cord.
- * Pay attention that the microscope should be placed near AC connector and the AC connector is touchable for users

4.2 The clamps fix the stage and focusing adjustment firmly during transportation.

Handle the grooves beside collector and pull it out. Remove the clamps by wrenches.

* Mechanical stage

There is one clamp fixing the mechanical stage in Y axis direction. Remove the bolts and clamps.

* Focusing adjustment

Pull out the collector. The bracket is fixed by one clamp. Please remove the bolts and clamps.

4.3 Mount the binocular head

Loosen the fixing screw in the eye tubes and insert the binocular head into the eye tubes. Then tighten the screw.

4.4 Mount the blue filter

Take out the filter from the bottom of condenser and mount it in the bracket then move the bracket into the condenser.



4.5 Adjustment and replacement

4.5.1 Condenser

The condenser is mounted in the microscope before shipment. Remove or replace the condenser according to the following steps

4.5.1.1 Turn the lifting knob for condenser and make the bracket in a suitable position

4.5.1.2 Loosen the screw in the left side of condenser and take out the condenser. Mount the blue filter in the bracket then move it into the bottom of the condenser. Make the label in the condenser forward and move the condenser into the bracket. At last tighten the screw.

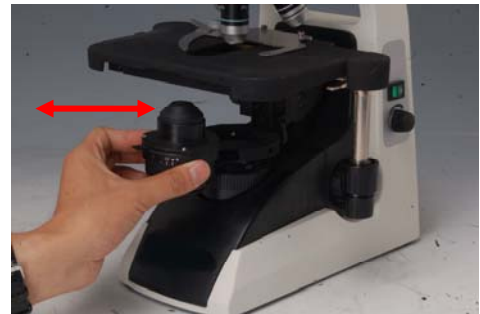

4.5.1.3 Turn the lifting knob of condenser and make the condenser to the highest position. The image will be focused in the right place of object (center of light path) when the light transit condenser. Move the condenser up and down a little to make the dispersion image disappeared.

4.5.2 Objectives

The objectives have been mounted in the microscope before shipment

The objectives have been mounted in the microscope before shipment

Take off the specimen from the stage and make the stage lower when you replace the objectives.

Handle the objective with your two hands and remove it. Be carefully do not make it fall off.

4.5.3 Specimen clip

The clip has been mounted in the stage before shipment

Loosen two screws by wrenches supplied by manufacturer to remove the clip.

4.5.4 Eyepieces

10X eyepieces have been in the foam box before shipment. Insert the eyepiece into the eyepiece tubes and tighten the fixing screws by wrench

Handle the eyepieces and replace them according to following picture

Left and right eyepiece should be replaced together when replacing to use 15X eyepiece to keep the same magnification between left and right eye tubes

Notice: The 10X eyepiece should touch the end of eye tube

The “O” scale should be consistent with standard line when the eyepieces are inserted in or pulled out of the eye tubes. Handle the eyepiece cover and never handle the diopter adjusting ring



4.5.5 Other

Replace other attachments (eg, camera) according to the instruction

4.6 Replacement

4.6.1 Replacement for bulb

4.6.1.1 Turn off the power supply (turn the switch to “O”) and pull out the connector

4.6.1.2 Wait for 30 minutes till the bulb is cooling

4.6.1.3 Handle the grooves in condenser and pull it out

4.6.1.4 Pull out the original bulb

4.6.1.5 Replace the bulb by gloves or cloth material then insert the bulb into the socket entirely

4.6.1.6 Pull the condenser back to its original position

4.6.1.7 Connect the electronic cord to the power supply

4.6.2 Replacement for fuse

4.6.2.1 Turn off the power supply (turn the switch to “O”) and pull out the connector

4.6.2.2 Open the cover for fuse by screwdriver

4.6.2.3 Mount the new fuse

4.6.2.4 Make sure that the voltage shown in the cover for fuse is same to the working voltage

4.6.2.5 Mount the cover



5. Operation

5.1 Illumination

Turn on the power supply (turn the switch to “-“) then the bulb will be on. The lightness can be adjusted by turning the adjusting knob.

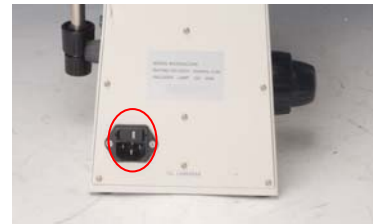

5.2 Interpupillary range

Adjust the siendentipf binocular to make sure that view field in the right and left eyepiece is consistent. The point “ • ” stands for the interpupillary distance

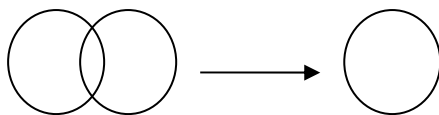

5.3 Put the slide in the stage and make the cover glass on it. Make the clips clamp them entirely. Two slides can be put in the stage in the same time



5.4 Focus by 10X objective

Put the 10X objective into the optic path and focus by turning coarse and fine focusing knob

* Turn the stage and focusing knob according to the direction shown in the picture

* There is no coarse focusing knob in one side of stage’s moving knob and in the other side there are both coarse and fine focusing knob

* Never turn the left and right focusing knob in the adverse direction at the same time. Never turn the coarse focusing knob when the stage is in the end of removing range. Otherwise it will make damage to the instrument

* It is difficult to do focusing if turning the focusing knob optionally. The specimen may be crushed when 100X objective is used. Please read the instruction carefully to avoid making damage to the cover glass or objective

5.4.1 Put the 10X or 4X objective into optic path

5.4.2 Remove the stage to the top by turning the coarse focusing knob

5.4.3 Observe through the eyepiece and turn the coarse focusing knob slowly to let the stage down and down till there is sharp image

5.4.4 Turn the fine focusing knob to focus finely

Use the 10X objective or 4X objective firstly before 40X and 100X objective. Turn the fine focusing knob to focus finely



5.5 Adjusting the diopter for eyepieces

Adjust the diopter ring according to user's diopter for left and right eyes. This function could make use of advantages of objectives fully. Meanwhile it also can be react as focusing

5.5.1 Put the 40X objective in the optic path and turn the coarse and fine focusing knob to do focusing

5.5.2 Put the 10X objective (or 4X objective) in the optic path

5.5.3 Let your left eye observe through the left eyepiece and do focusing by the diopter adjusting ring in left eyepiece

5.5.4 Repeat the above steps till sharp image can be observed by left and right eyepiece at the same time.



5.6 Adjusting the upright position for condenser

Turn the lifting knob for condenser till it reaches the top position then fall it a little bit down. If there is dispersion image in the view field, please remove the condenser a little bit of up and down to make the dispersion image disappeared

5.7 Objectives

Turn the nosepiece to choose the objective and adjust the view field diaphragm and aperture accordingly

5.8 Adjusting aperture diaphragm

Adjust the aperture diaphragm adjusting shaft for condenser till the position which stands for the magnification of objective

* adjust the aperture diaphragm

5.8.1 Adjust the aperture diaphragm by the adjusting shaft. The brightness and resolution will be decrease while the contrast and depth of view will increase if the diameter of aperture diaphragm reduces

5.8.2. Adjust the value of aperture diaphragm to 70%~80% of the value of objective's N.A.

5.8.3 The aperture diaphragm could control the N.A. of condenser. Do not adjusting the brightness by it while use the brightness adjusting knob to make the adjustment

5.8.4 N.A. is marked in each objective

e.g. 40X/0.65 stands for that magnification is 40X and N.A. is 0.65

5.8.5 Remove the eyepiece and observe through the eye tubes by eyes directly

N.A. of condenser could tell users the position of aperture diaphragm adjusting shaft in corresponding magnification. (That is to say, the value of aperture diaphragm should be 70% to 80% of the N.A. of objective when the aperture diaphragm adjusting shaft reaches some position) If the objective has been changed, please move the shaft to the position with the same value which is in the objective in the optic path and this will make ideal contrast



5.9 Observing with oil immersion

There is “oil” marked in the oil immersion objective. Please use the oil immersion supplied by the manufacturer between the objective and cover glass

5.9.1 Operation

5.9.1.1 Condenser

Remove the slide back and fall the condenser down a little. One drop of oil could be placed in the top of condenser by through the long aperture of stage. Then move the slide forward and lift the condenser up



5.9.1.2 Objectives

Turn the nosepiece and take the objective out of the optic path. Place one drop of oil on the slide then turn the condenser slowly and mount the objective

5.9.2 Air bubble in oil immersion

5.9.2.1 Never make the oil immersion into your eyes. Please take following steps as soon as the oil immersion touches your skin or eyes

Use soap or clean water to wash your skin carefully

Please wash your eyes with clean water (at least wash 15 minutes) and go to the hospital at once

5.9.2.2 Do not expose the oil immersion in the sun or ultraviolet radiation directly

As the air bubble in the oil immersion will make bad affect to the quality of image, please make sure that there is no air bubble in the oil immersion before use. Please check the air bubble as following, remove the eyepieces and open the view field diaphragm and aperture diaphragm entirely then observe the exit pupil which is light and in nummular shape

5.9.2.3 Remove the air bubble as following

Turn the nosepiece slowly and turn the oil immersion objective once or twice

Turn the lifting knob for condenser slowly and make the condenser a little bit of up and

down

Increase the amount of oil immersion or change the old oil immersion with new one

5.9.3 Operation for oil immersion

Use the oil immersion as little as possible. The oil immersion will be conglutinated to the stage and condenser and this will have bad effect the performance if there is too much oil immersion. Please clean the redundant oil on the objective and condenser after finishing the observation otherwise the image will be affected. Use the aether to clean the oil then use the pure alcohol (ethanol or carbinol) to make entirely cleaning. Please repeat the clean three or four times.

Notice: Please follow the instruction from manufactures when the aether or pure alcohol is used. Keep them away from the fire or electronic spark

5.9.4 Attention

5.9.4.1 Keep the bottle for oil immersion sealed as much as possible and check it periodically

5.9.4.2 Never press the bottle overly as it may caused oil gushed out of the bottle

5.9.4.3 Clean the out surface of the bottle from remanent oil

5.10 Adjusting the coarse focusing knob's tension

The tension of coarse focusing knob is adjustable. Please turn the tension controlling ring of the coarse focusing knob clockwise then the tension will be increased. This ring is near the coarse focusing knob. If you want decrease the tension, please turn the ring withershins. The stage will fall down automatically if the tension of the ring decreased too much



5.11 Micrography

The image from microscope could be get by camera, digital camera and CMOS/CCD camera

5.11.1 Installation and operation for CMOS/CCD camera

5.11.1.1 Installation

* It is similar to assemble the eyepiece tube, just tighten the screw to fix it. Connect the CMOS or CCD camera with the adaptor and insert it in the photo tube. Adjust the image to be correct then tighten the screw.

* Use the USB cable to connect the CMOS or CCD camera and the computer. (Please read the instruction in the software to see how to use the software)

5.11.1.2 Operation

* Observe through the 10X eyepieces before photography. Do focusing as the above steps till sharp image of the specimen displayed by the software and do not do any adjustment to the camera system

* If the image from the software is too bright or dark, please turn the power supply's brightness adjusting knob to adjust brightness of the illumination

* Turn the fine focusing knob to make the microscope is exactly on the focusing plane. Then turn the diopter adjusting ring on the eyepieces to make sure them are on focus

5.11.2 Installation for Canon 650 digital camera

Connect the photo adaptor with the Canon 650 digital camera. Then insert it into the photo tube. Adjust it till get sharp image then tighten the fixing screw. The operation is same as the above of CMOS/CCD camera.

6. Troubleshooting

The performance of the microscope can't be made fully by unfamiliar using and this table will give some

advices. Please the following table and please contact with manufacturer if the troubles could not be solved.

1. Optical

Trouble	Cause	Remedy
Darkness at the periphery or uneven view field brightness	Revolving nosepiece not in click stop position (objective not centered in optical path)	Revolve to click position (switch the objective correctly into the optical path)
	Filament image not in center	Centering
	Dirt or dust on the lens (condenser, objective, eyepiece, collector)	Cleaning
Dirt or dust in the view field	Dirt or dust on the lens (condenser, objective, eyepiece, collector)	Cleaning
	Dirt or dust on the slide	Cleaning
	Condenser position too low	Correct position
Poor image quality (low resolution poor contrast)	No cover glass on the specimen	Attach cover glass
	Cover glass too thick or thin	Use cover glass of specified thickness (0.17mm)
	Slide upside-down	Turn over the slide
	Immersion oil on dry objective (especially 40X)	Cleaning
	Dirt or dust on the lens (condenser, objective, eyepiece, collector)	Cleaning
	No immersion oil used on immersion objective	Use immersion oil
	Air bubbles in immersion oil	Remove air bubbles
	Unspecified immersion oil used	Use specified immersion oil
	Condenser aperture and field	Close properly
	Dirt or dust on the entrance lens	Cleaning
	Condenser aperture closed too far	Close properly
	Condenser position too low	Raise to the position where the field diaphragm image is in focus
	Condenser not in the center of the view field or condenser inclined	Reinstall condenser and carefully adjust with centering screw
Image shift on one side	Revolving nosepiece not in click stop position	Revolve to click-stop position
	Floating specimen	Fasten securely
Insufficient illumination brightness	Specimen rise from stage surface	Place it stable
	Revolving nosepiece not in click stop position	Revolve to click-stop position
Image tinged yellow	Blue filter not used	Use blue filter
Insufficient illumination brightness	Condenser aperture too small	Readjust aperture
	Condenser position too low	Correct position
	Dirt or dust on the lens (condenser,	Cleaning

	objective, eyepiece, collector)	
--	---------------------------------	--

2. Mechanical

Trouble	Cause	Remedy
Image not focusable with high power objective	Slide upside-down	Turn slide cover
	Cover glass too thick	Use cover glass of specified thickness (0.17mm)
High power objective contacts slide when changed-over from low power	Side upside down	Turn slide over
	Cover glass too thick	Use cover glass of specified thickness (0.17mm)
Specimen movement unsmooth	Mechanical stage not securely fastened	Tighten all fastener
Binocular images not integrated	Interpupillary distance not correctly adjusted	Adjustment
Excessive eye fatigue	Incorrect diopter adjustment	Correct adjustment
	Inadequate brightness or illumination	Adjust brightness with control dial

3. Electrical

Trouble	Cause	Remedy
Lamp does not light when switched ON	No electrical power	Check power cord connection
	Lamp bulb not inserted	Insert correctly
	Lamp failure	Replacement
Sudden lamp failure	Unspecified lamp bulb used or input voltage too high	Replace with specified lamp bulb. If the same symptom occurs after replacing the lamp, contact your dealer
Insufficient illumination brightness	Unspecified lamp bulb used	Replace with specified lamp bulb
	Voltage too low	Increase brightness with control dial
Flickering or unstable lamp brightness	Lamp bulb about to fail	Replacement
	Lamp bulb not correctly inserted into socket	Check for positive connection

7. Maintenance

1. Cleaning Lenses

Dust is best removed with a soft brush or gauze.

More persistent dirt, such as fingerprints, grease and oil, may be removed with soft cotton, lens tissue, or gauze lightly moistened with absolute alcohol (ethyl or methyl alcohol).

To clean immersion oil off the oil-immersion type objective, use lens tissue, soft cotton or gauze lightly moistened with petroleum benzene only.

Do not use petroleum benzene to clean the entrance lens at the bottom of the eyepiece tube or prism surfaces inside the eyepiece tube.

Absolute alcohol and petroleum benzene are quite inflammable. Take great care when handling them and when setting the power switch on and off. Be very careful with fire.

2. Cleaning painted or plastic surfaces

Avoid use of and organic solvents (such as alcohol, ether, thinner,ect.) to clean the painted or plastic surfaces of the instrument. We recommend the use of silicon cloth.

More persistent dirt may be cleaned with mild detergent solution.

Printed plastic surfaces should be cleaned only by soft cloth moistened with water.

3. When not in use

When the microscope is not in use, cover it up with dust cover, and store in a dry place not subject to mold.

We especially recommend that the objectives and eyepieces be kept in a container (such as a desecrator).

4. Periodical inspection

To maintain the performance of the microscope, periodical inspection is recommended.