

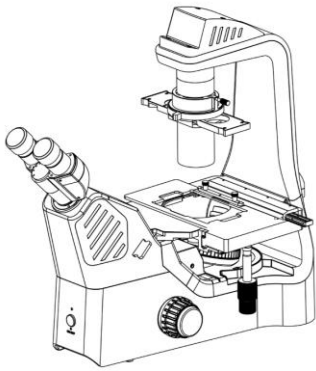

BS-2094 Series

Inverted Biological Microscope

Instruction Manual



BS-2094A

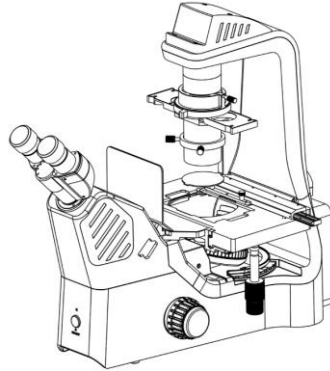

BS-2094AF

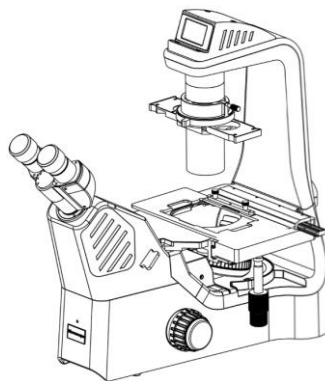

BS-2094B

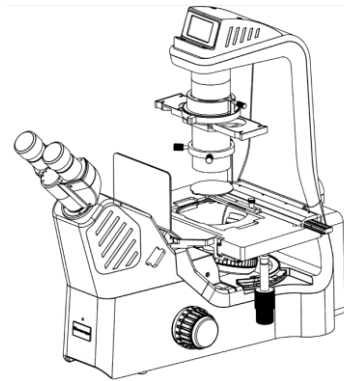

BS-2094BF











This instruction manual is intended for users of the Inverted Series Biological Microscope BS-2094. To ensure safety use, perform the best performance and to familiarize yourself with the use of this microscope, please read this manual carefully before operating this product.

Contents

Before Using	1
Safety Symbol.....	1
Safety Precautions	1
Care and Maintenance.....	2
Chapter 1 Introduction	4
1.1 Technical Specifications	4
1.1.1 Main Technical Specifications and Configuration.....	4
1.1.2 Objective Parameters.....	5
1.1.3 Electrical Parameters.....	5
1.2 Components	6
Chapter 2 Overview of Agencies	8
Chapter 3 Regulation and Operation	12
3.1 Turning the Power on	12
3.2 Turning the Illumination switch on.....	12
3.2.1 Manual Lighting Switch.....	12
3.2.2 ECO Switch (Optional functions)	12
3.3 Adjusting the Illumination Brightness.....	13
3.4 Specimen Placement and Stage Knob Adjustment.....	13
3.4.1 Mechanical Stage.....	13
3.4.2 Pallet.....	14
3.4.3 Auxiliary Stage.....	14
3.5 Adjusting the Interpupillary Distance.....	14
3.6 Focusing on the Specimens	15
3.6.1 Focus Knobs.....	15
3.6.2 Focus Knob Tight Adjustment	15
3.7 Adjusting the Diascopic Illumination Aperture Diaphragm.....	16
3.8 Switching the Objective.....	16
3.9 Operation the Phase Contrast Microscope.....	17
3.10 Operation the Emboss Contrast Microscope	18
3.10.1 Condenser-side Emboss Contrast Slider.....	18
3.10.2 Eyepiece-tube-side Emboss Contrast Slider	18

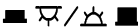
3.11 Operating the Episcopic Illumination Microscopy.....	19
3.11.1 Episcopic Illumination.....	19
3.11.2 Fluorescence Filter Cube Turret	19
3.11.3 Filter Cube Switching Unit	19
3.11.4 Fluorescence Filter Cube.....	20
3.11.5 Fluorescence LED Unit	20
3.12 Operating the LCD	21
3.12.1 The status of LCD	21
3.12.2 Operating the illumination switch	21
Chapter 4 Assembly.....	22
4.1 Installation diagram	22
4.2 Installation Steps	23
4.2.1 Installing the Condenser	23
4.2.2 Installing the Phase Contrast Slider	23
4.2.3 Installing the Moving Ruler	23
4.2.4 Installing the Objective	24
4.2.5 Installing the Eyepiece	24
4.2.6 Installing the LED Light Box	24
4.2.7 Installing the Camera.....	25
4.3 Assembly Episcopic Illumination Microscopy.....	26
4.3.1 Installing the Filter Cube	26
4.3.2 Installing the Fluorescence LED Unit	26
4.3.3 Replacing the Fuse	26
Chapter 5 Maintenance and Storage.....	27
5.1 Cleaning	27
5.1.1 Cleaning the Lenses	27
5.1.2 Cleaning Parts other than Lenses	27
5.1.3 Cleaning off Immersion Oil	28
5.1.4 Decontaminating this Product	28
5.2 Storage	28
Chapter 6 Troubleshooting	29
6.1 Optical System	29
6.2 Mechanical Parts	29
6.3 electrical Parts.....	30

Safety Symbol

Symbol	Description
	The surface is hot and cannot be touched with bare hands.
	Please read this manual carefully before using the product. Incorrect usage can cause personal injury or property damage.
	The main power switch is turned on.
	The main power switch is turned off.
	Adjustment direction of illumination.
	Ground connection.
ECO	People go lights out switch.
	Up and down light switch.
 ON/OFF	Light switch.
	Through the CE certification.
	Lever in, Bino: Trino=100: 0
	Lever out, Bino: Trino=0: 100

Safety Precautions

1. Be careful when opening box, prevent lens glass to stick to fingerprint, perspiration other factors influence observation, prevent lens and other attachment drop damaged.
2. Avoid placing the microscope in place with direct sunlight, high temperature or high humidity, dust, and strong vibration. Ensure that the stage is flat, horizontal and strong enough.
3. If a bacterial solution or water spatters spill on the stage, objective or observing tube, immediately unplug the power cord. Then, wipe off any solution or water with to keep the microscope dry. Otherwise, it could damage the instrument.
4. To avoid blocking the natural convection air for cooling, make sure the left, right, top, and rear of the microscope are at least 10 centimeters away from the wall and other objects.

5. Grounding the machine to avoid lightning strike.
6.  To ensure safety, always make sure the main switch is in "O" (disconnecting) and cut off the power while waiting for the LED lights and the lamp room to cool completely. Input voltage check: the input voltage indicated on the back of the microscope is consistent with the supply voltage, otherwise the microscope will be seriously damaged.
7. Use our company dedicated wire.
8. When carrying this product, one hand should firmly hold it by gripping the recess in the front lower part of the main body and the other holds the recess in the rear of the main body.

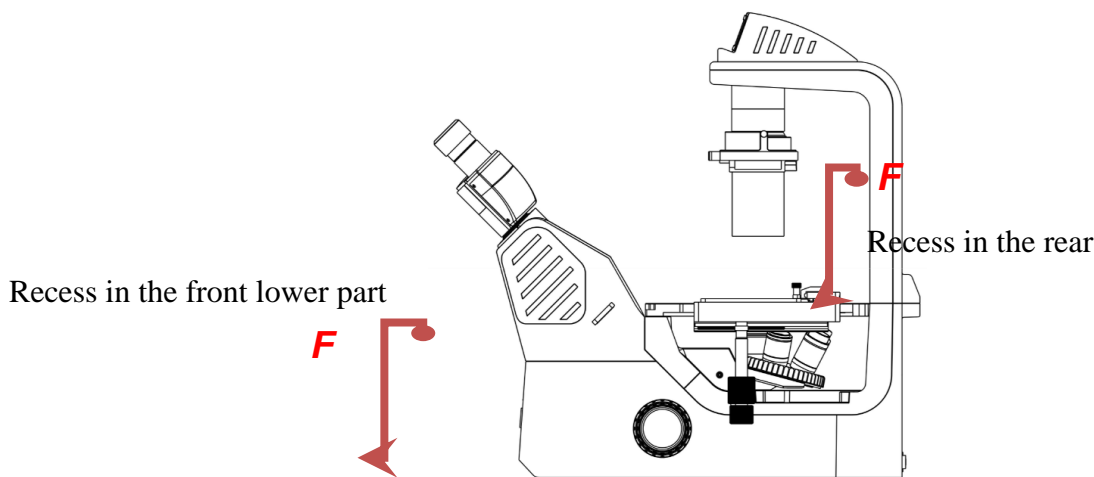

★ Do not hold any other parts (such as the upper part of the illumination pillar, focus knobs, eyepiece tube, or stage) when carrying the microscope. Doing so might result in dropping or failure of this microscope.

Care and Maintenance

1. All lenses have been calibrated, please do not disassemble by yourself.
2. The structure of objective converter and coarse and fine focus mechanism are precise, please do not disassemble easily.
3. The instrument should be kept clean, have to regular removal of dust, special attention should be paid to do not contaminate the optical parts when cleaning.
4. The stain of the lens, such as fingerprints and grease can be wiped with a small amount of ethyl ether (70%) and alcohol (30%) mixed solution.



Because the solvent such as ether and alcohol are extremely flammable, do not operate power switch of various electrical equipment when using, and keep away from open fire, please ensure indoor ventilation.

5. Do not use organic solvents to clean the non-optical parts of the microscope. Please use neutral detergents when cleaning.
6. When using, if the microscope be wet liquid, should immediately cut off the power and dry.
7. Do not disassemble any part of the microscope, which will affect the function or reduce the performance of the microscope.
8. The instrument should be placed indoor with cool and dry, covered the dust cover when not in use. Cover up, must wait for the lamp room to cool down.
9. The microscope usage environmental requirements:
 - a) For indoor use;
 - b) The environment temperature range: 10 °C ~ 35 °C;
 - c) Maximum relative humidity: 80% at 31 °C, linear temperature down to 34 °C is 70%, 60% at 37 °C, 50% at 40 °C.
10. Microscope to store and transport environment requirements:
 - a) the environment temperature range: - 40 °C ~ + 70 °C
 - b) relative humidity range: 10% ~ 100%
 - c) atmospheric pressure range: 500 hpa ~ 1060 hpa

Chapter 1 Introduction
BS-2094
1.1 Technical Specifications
1.1.1 Main technical specifications and configuration

Device	Technical Specifications	BS-2094A	BS-2094AF	BS-2094B	BS-2094BF
Eyepiece	Extra Wide Field Eyepiece 10×/22	●	●	●	●
	Field Eyepiece 15×/16	○	○	○	○
	Field Eyepiece 20×/12	○	○	○	○
Observation head	Seidentopf Viewing Head, Inclined at 45°, Interpupillary 48-75mm	●	●	●	●
Objective	Infinity plane objective 4×	●	○	●	○
	Infinity plane objective 10×	○	○	○	○
	Infinity plane objective 20×	○	○	○	○
	Infinity plane objective 40×	○	○	○	○
	Infinity plane Phase contrast objective 4×	○	○	○	○
	Infinity plane Phase contrast objective 10×	●	○	●	○
	Infinity plane Phase contrast objective 20×	●	○	●	○
	Infinity plane Phase contrast objective 40×	●	○	●	○
	Infinity plane semi-apochromatic objective 4×	—	●	—	●
	Infinity plane semi-apochromatic objective 10×	—	●	—	●
	Infinity plane semi-apochromatic objective 20×	—	●	—	●
	Infinity plane semi-apochromatic objective 40×	—	●	—	●
Nosepiece	Quintuple Nosepiece	●	●	—	—
	Quintuple intelligent Nosepiece	—	—	●	●
Focusing mechanism	up 7mm, down 1.5mm, to limit up to 18.5mm	●	●	●	●
Centering telescope	lens tube ϕ 30	●	○	●	○
stage	250mm×170mm	●	●	●	●
Moving stage	Y- 80mm, X- 128mm	●	●	●	●
Plain stage	Two plain stages	○	○	○	○
Condenser	NA=0.3, WD=75	●	●	●	●
illumination	Transmitted illumination: 3WLED	●	●	●	●
	Fluorescent illumination: (B, G, U) 3WLED	—	●	—	●
	Fluorescent illumination: V, 3WLED	○	○	○	○
Universal phase contrast slider	4×, 10×/20×/40× (for phase contrast)	●	●	●	●
	4×, 10×/20×, 40×, 60× (for semi-apochromatic contrast)	○	○	○	○
Emboss contrast slider	contrast slider	○	○	○	○
Camera mount	C-Mount 1×	●	●	●	●
	C-Mount 0.5×	○	○	○	○
LCD		—	—	●	●

Note: ● Standard component, ○ Choose component, — Inapplicability

Optional Objective

No.	Technical Specifications
1	Infinity plan semi-apochromatic objective (adjustable) 20×, 40×, 60×
2	Infinity plan semi-apochromatic phase contrast objective (adjustable) 20×, 40×, 60×
3	Infinity plan semi-apochromatic phase contrast objective 4×, 10×, 20×, 40×, 60×

1.1.2 Objective parameters

Type	BS-2094A/BS-2094B				BS-2094AF/BS-2094BF			
	4×	10×	20×	40×	4×	10×	20×	40×
Magnification	4×	10×	20×	40×	4×	10×	20×	40×
Numerical aperture(N.A)	0.10	0.25	0.40	0.60	0.13	0.30	0.45	0.60
Work distance (mm)	30	10.2	12	2.2	17	7.4	8	3.6
Cover-glass thickness	0.17	0.17	0.17	0.17	1.2	1.2	1.2	1.2
Conjugate distance(mm)	∞	∞	∞	∞	∞	∞	∞	∞

1.1.3 Electricity parameter

	Item	BS-2094A/BS-2094B	BS-2094AF/BS-2094BF
1	Input voltage	AC100-240V; 50/60 Hz	
2	Fuse Size	T500 mA; 250 V	
3	LED light	3W S-LED	
4	Fluorescence LED light (B light)	—	wavelength is 485nm at 3W
5	Fluorescence LED light (G light)	—	wavelength is 520nm at 3W
6	Fluorescence LED light (U light)	—	wavelength is 360nm at 3W

1.2 Components

The microscope BS-2094A components (following diagrams), BS-2094B add LCD based on BS-2094A.

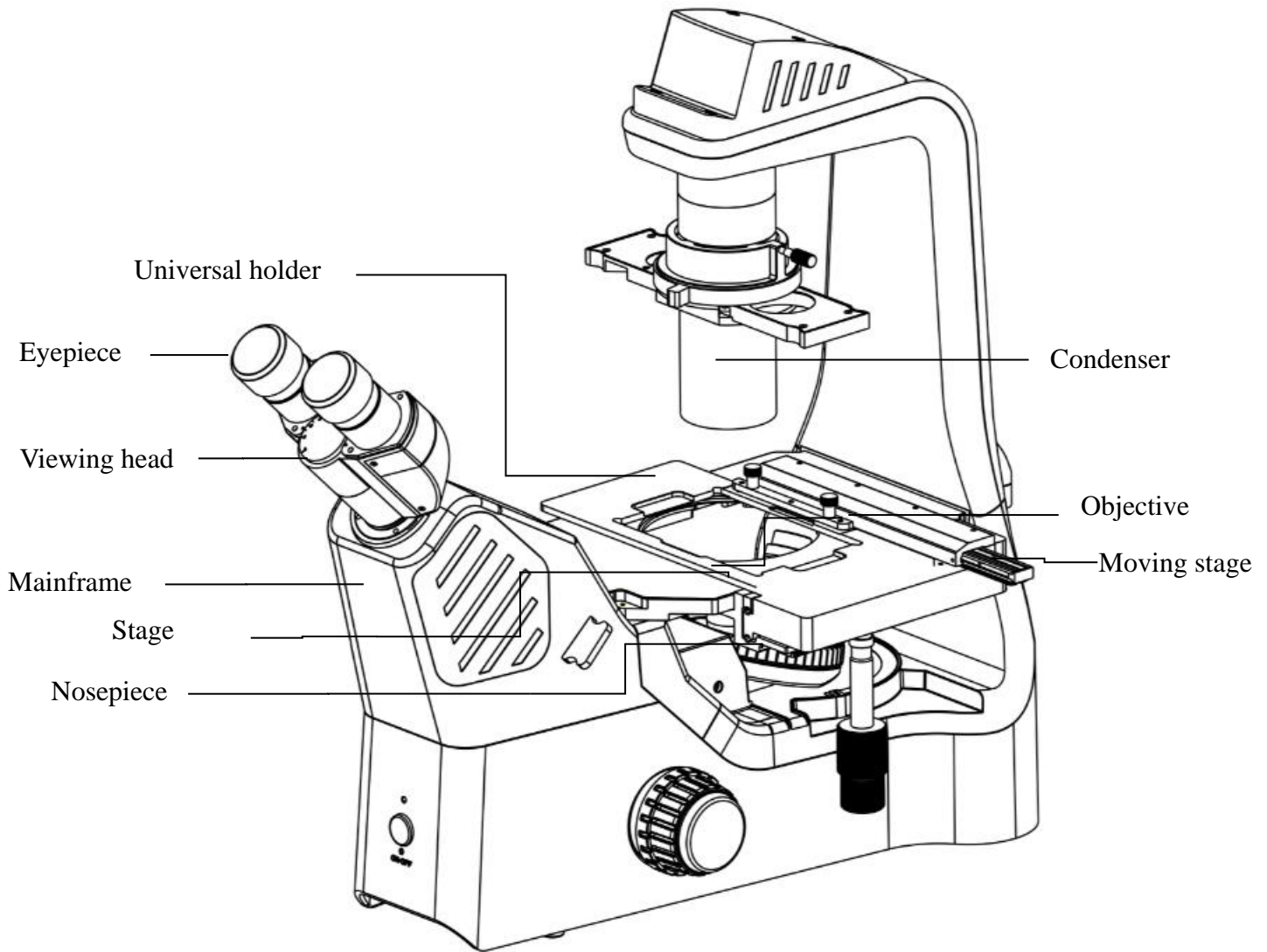

BS-2094A

The microscope BS-2094BF components (following diagrams), BS-2094AF = BS-2094BF remove LCD screen.

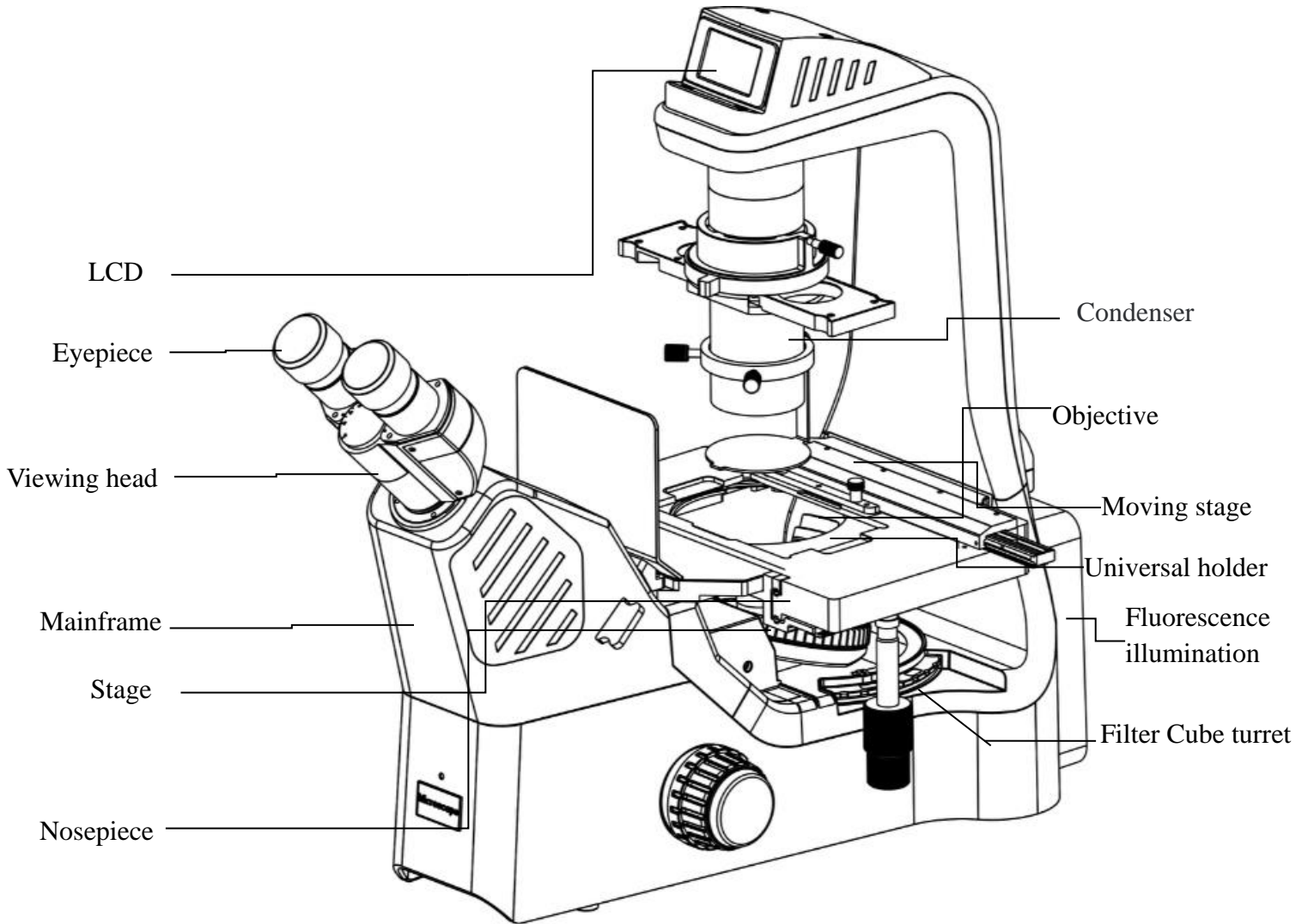

BS-2094BF

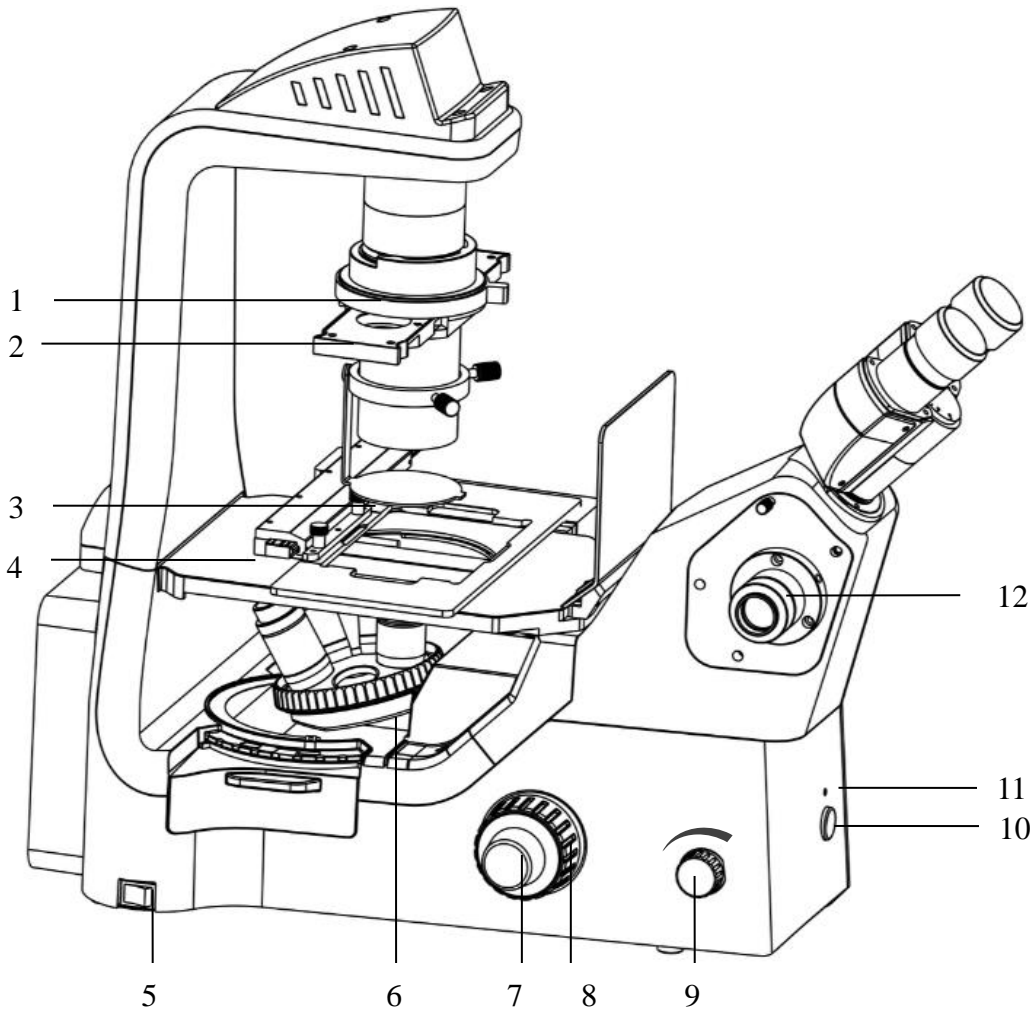

BS-2094AF

- | | | | |
|---|---------------------------------------|----|--|
| 1 | Condenser aperture adjustment knob | 7 | Fine focus knob |
| 2 | Contrast slider | 8 | Coarse focus knob |
| 3 | Upper lighting shading part (only FL) | 9 | Brightness adjusting knob |
| 4 | Stage | 10 | Up/ down illumination switch (Transmitted illumination for biological model) |
| 5 | Power switch | 11 | Power indicator |
| 6 | Nosepiece | 12 | Camera C-mount |

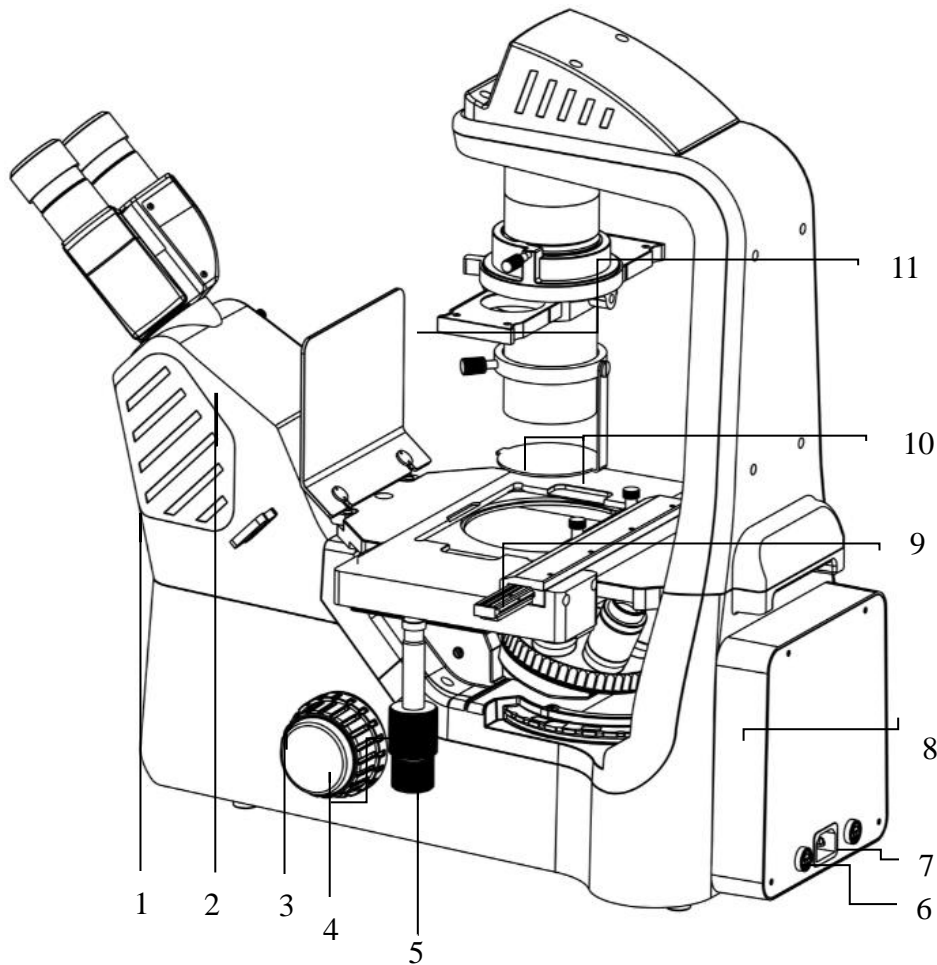

BS-2094AF

- | | | | |
|---|---|----|---------------------------|
| 1 | Emboss contrast slider | 9 | Moving stage |
| 2 | Fluorescent baffle (only FL) | 10 | Universal bracket/ holder |
| 3 | Elastic adjustment knob | 11 | Condenser set screw |
| 4 | Bracket horizontal movement knob | | |
| 5 | Bracket vertical movement knob | | |
| 6 | Fuse | | |
| 7 | Outlet | | |
| 8 | Built-in fluorescent light source part and fuse (only FL) | | |

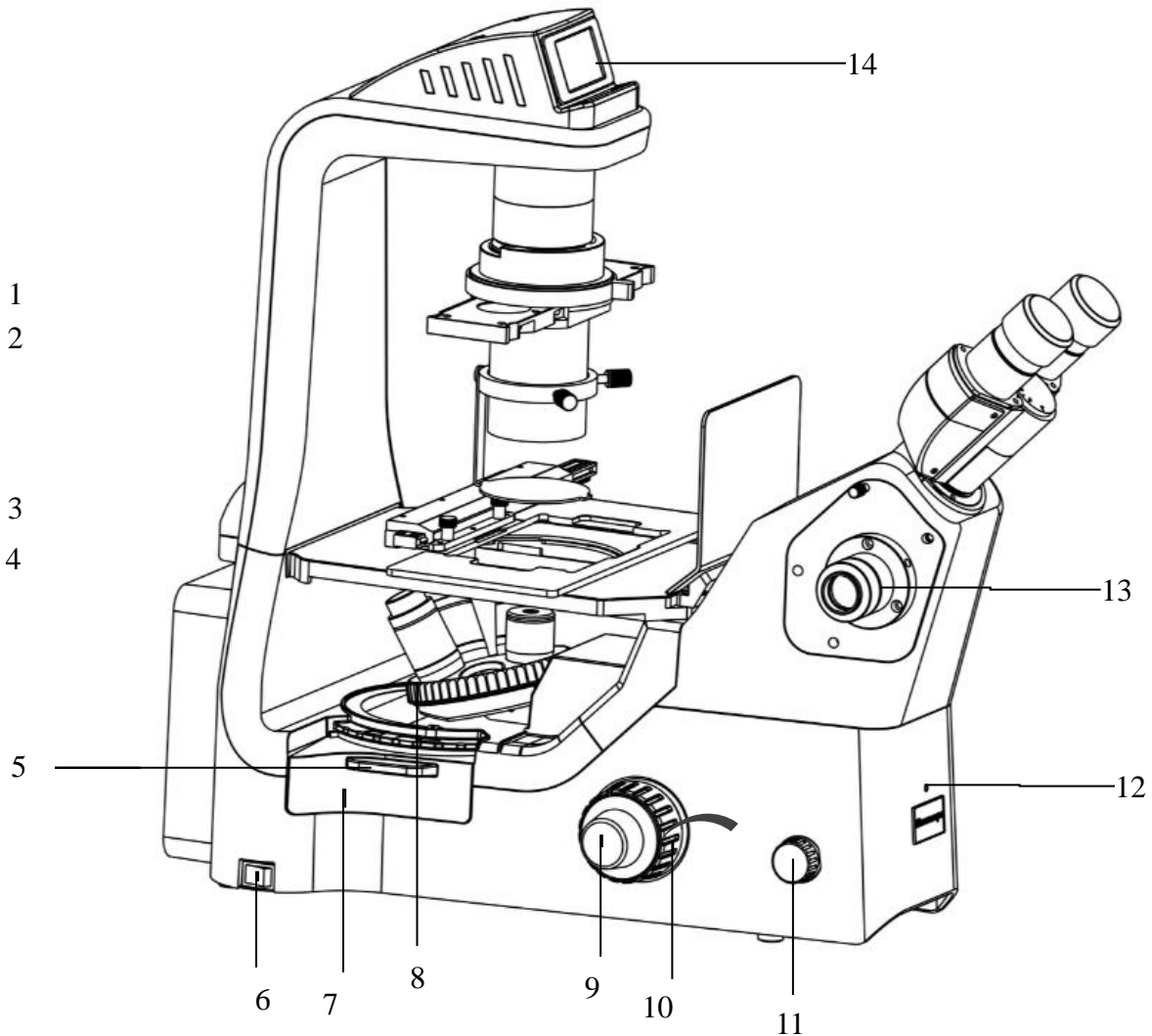

BS-2094BF

- | | | | |
|---|-------------------------------------|----|---|
| 1 | Condenser aperture adjustment knob | 9 | Fine focus knob |
| 2 | Contrast slider | 10 | Coarse focus knob |
| 3 | Universal bracket/ holder set screw | 11 | intelligent adjuster (only BS-2094B series) |
| 4 | Stage bracket/ holder | 12 | Power indicator |
| 5 | Fluorescence cube turret (only FL) | 13 | Camera mount |
| 6 | Power switch | 14 | LCD (only BS-2094B series) |
| 7 | Turntable cover (only FL) | | |
| 8 | Nosepiece clamp screw | | |

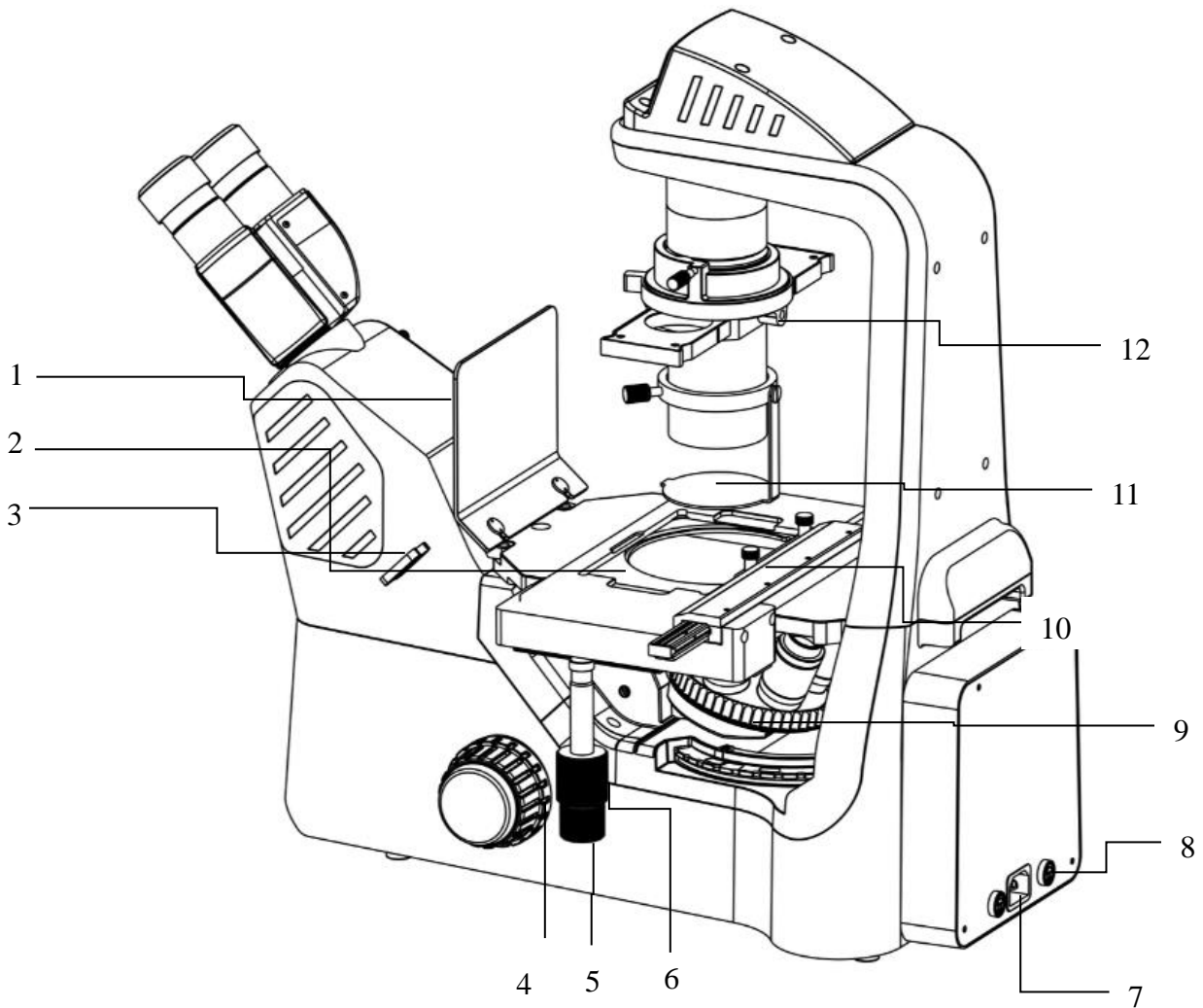

BS-2094BF

- | | | | |
|---|---------------------------------|----|--|
| 1 | Fluorescent baffle (only FL) | 8 | Built-in fluorescent light source and fuse (only FL) |
| 2 | Universal bracket/ holder | 9 | Nosepiece |
| 3 | Emboss contrast slider | 10 | Moving ruler (attachable mechanical stage) |
| 4 | Elastic adjustment knob | 11 | Upper lighting shading part (only FL) |
| 5 | Stage X-direction movement knob | 12 | Condenser set screw |
| 6 | Stage Y-direction movement knob | | |
| 7 | Outlet | | |

3.1 Turning on the Power

Turn on the power and turn on the main switch which is at the back of the microscope body to "-" (on).

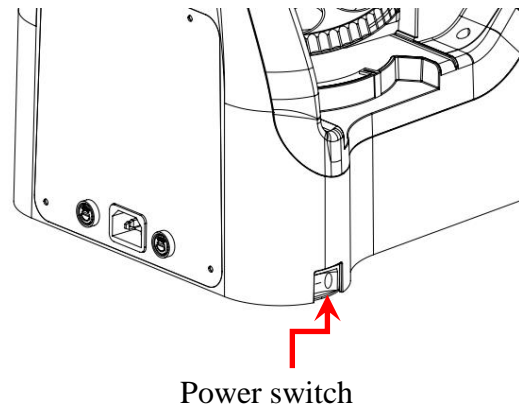

3.2 Turning the Illumination on

3.2.1 Manual lighting switch (for BS-2094A series)

Make sure the power indicator is on and press the light switch.

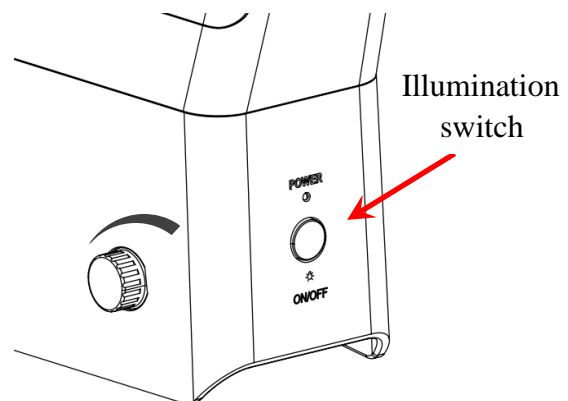

3.2.2 ECO switch (Optional functions)

As shown in figure, the induction device can sense objects within 0.5m in front of it.

When someone is observing within 0.5m in front of the microscope, the blue light in the induction device is on, the light source of the microscope will not be turned off. When the person leaves and without any other object within 0.5m in front, the blue light is off automatically. And after 15 minutes, the LED will be off. Press the ECO function key to open the lighting again.

Closing ECO: Pressing the ECO function key until the blue light go out.

Recovering ECO: restart the power.

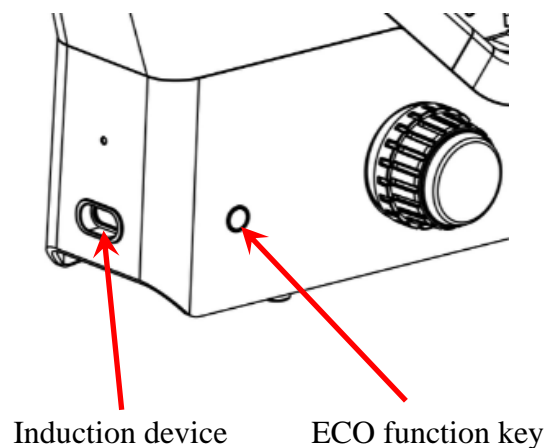

3.3 Adjusting the Illumination Brightness

As shown in the direction of rotation, the light source is enhanced, whereas the light source weakened.

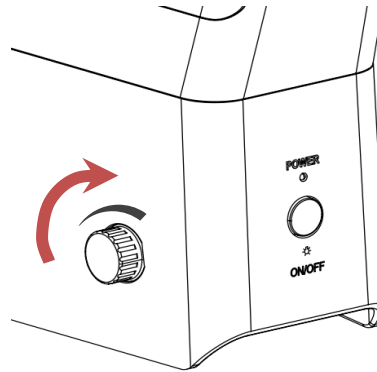

3.4 Specimen Placement and Stage Knob Adjustment

Load the slide holder into a mechanical stage, and the cover glass slides downward slowly into the grooves of the slide plate.

Rotate the stage knob to place the sample to the desired position.

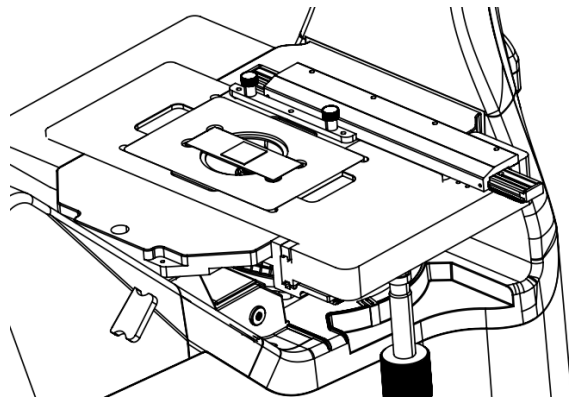

CAUTION

Be careful when changing the objective. The objective may collide with the specimen, because of the short working distance of specimen observation.

3.4.1 Moving stage

The Moving stage is mounted and used on the plain stage. The specimen can be moved in the X-axis and Y-axis directions by operating the stage knobs.

A 128×80 mm microplate can be placed on the Moving stage. Attaching the different specimen holders enables you to observe various types of specimens.

The upper is the vertical knob, and rotates in the direction as shown in the figure, the stage will move forward in the vertical direction. The lower is the horizontal knob rotating in the direction shown in the figure. The stage will move to the left in the horizontal direction.

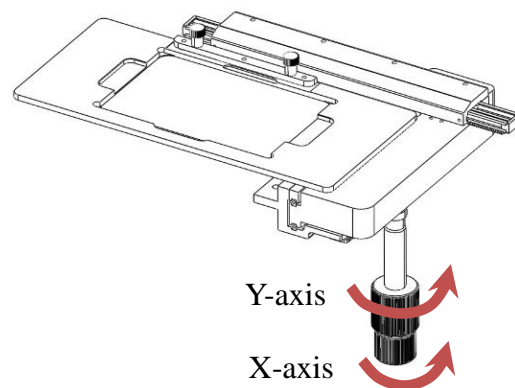

3.4.2 Holders

There are a variety of holders to choose from.

NO.	Model
1	Terasaki microplate
2	Universal holder
3	54mm Petri dish holder/ Slide holder
4	60 mm Petri dish holder/ Slide holder
5	90 mm Petri dish holder

3.4.3 Auxiliary stage

Connect the auxiliary stage to the left and right of the stage to expand the stage width. After connecting the auxiliary stage, the stage width is 300 mm.

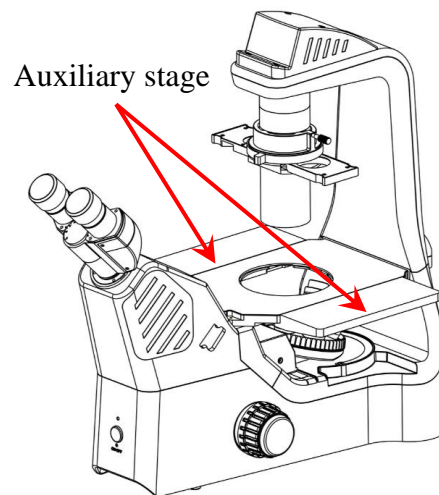

3.5 Adjusting the Interpupillary Distance

By rotating the binocular part while looking through the eyepieces, adjust the distance between the eyepieces so that the right and left view fields overlap to a single image from eyepieces

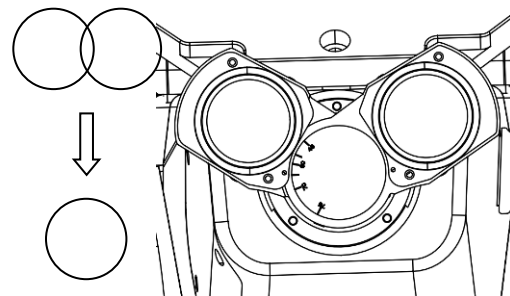

3.6 Focusing on the Specimens

3.6.1 Focus knob

To adjust the focus, rotate the focus knobs on the right and left sides of the microscope to move the objective up and down.

The figure to the right illustrates the relationship between the rotational direction of the focus knobs and the vertical motion of the objective.

Focus travel: from the focal point, up to 7mm and down to 1.5mm, and the limit can be up to 18.5mm. (As the right figure, spin out the limit screw for about 4 mm trip to limit)

The traveling distance of the objective for each knob is as follows:

Rotation of knob	Distance traveled by objective
Fine focus knob: 1 rotation	0.2 mm
Coarse focus knob: 1 rotation	37.7 mm



CAUTION

Never attempt the following operations, as they might result in product malfunction:

- ◆ Rotating the left and right focus knobs in opposite directions.
- ◆ Rotating the coarse and fine focus knobs past their limit.

3.6.2 Focus knob tight adjustment

The focus knob become tighter, when rotating direction of the tightness adjustment knob is shown as figure 8. Otherwise become more relaxed.

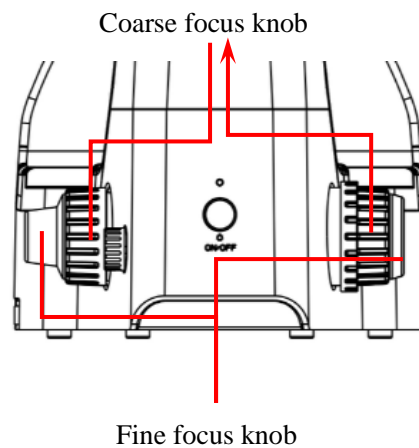
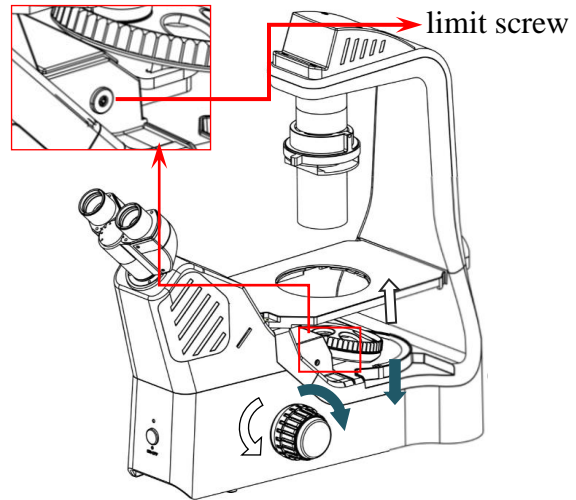

Tightness adjustment knob

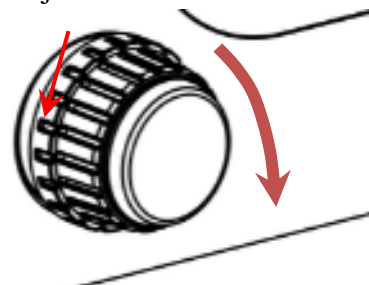

3.7 Adjusting the Transmitted Illumination

Aperture Diaphragm

Insert a centering telescope in the eyepiece tube, adjust the focal length, and view the objective pupil plane (a bright circle) and the aperture diaphragm image. Adjust the aperture diaphragm so that the size of the diaphragm image is 70-80% of the size of the objective pupil plane.

Aperture diaphragm is designed for the adjustment of numerical aperture, not the dimmer. Typically, adjusting the aperture diaphragm to 70% to 80% of the pupil of the objective will result in an appropriate contrast and a favorable image. The iris aperture adjusting handle is marked with the aperture of the diaphragm.

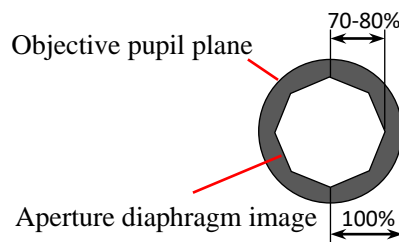
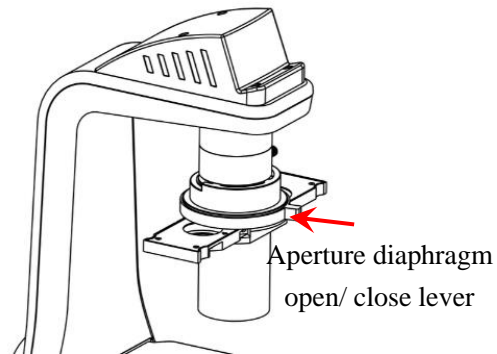

3.8 Nosepiece

Turn the nosepiece until it clicks in place, stays in the specified position, can switch the objective.

Before rotating the converter, check the objective height to prevent collision with specimens or stage.

Normally, the objective is mounted by rotating the nosepiece clockwise (from above the nosepiece) increasing magnification in turn.

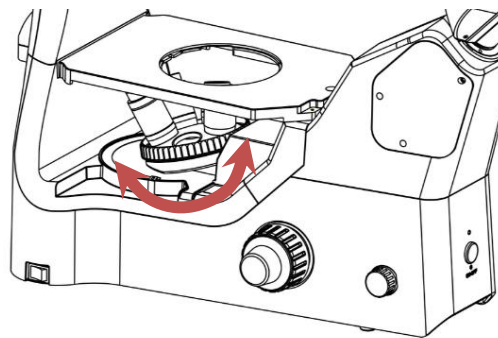

CAUTION

Be careful when changing the objective. The objective may collide with the specimen, because of the short working distance of specimen observation.

3.9 Operation the Phase Contrast Microscope

Phase contrast microscopy requires phase contrast (PH) objectives and PH sliders.

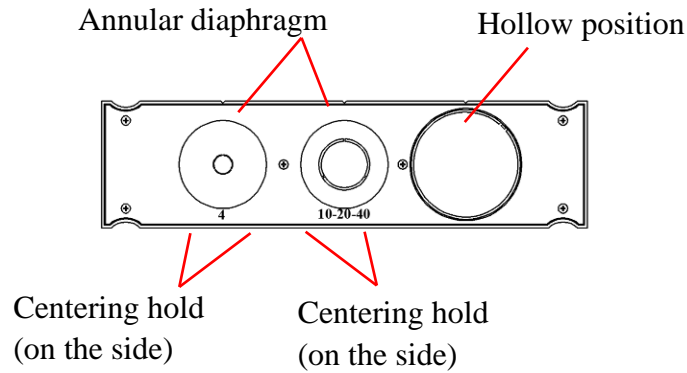

If PH Slider is used, it is possible to center the annular diaphragm. Turn the centering screw of the PH slider to merge the annular diaphragm image with the phase ring image in the objective.

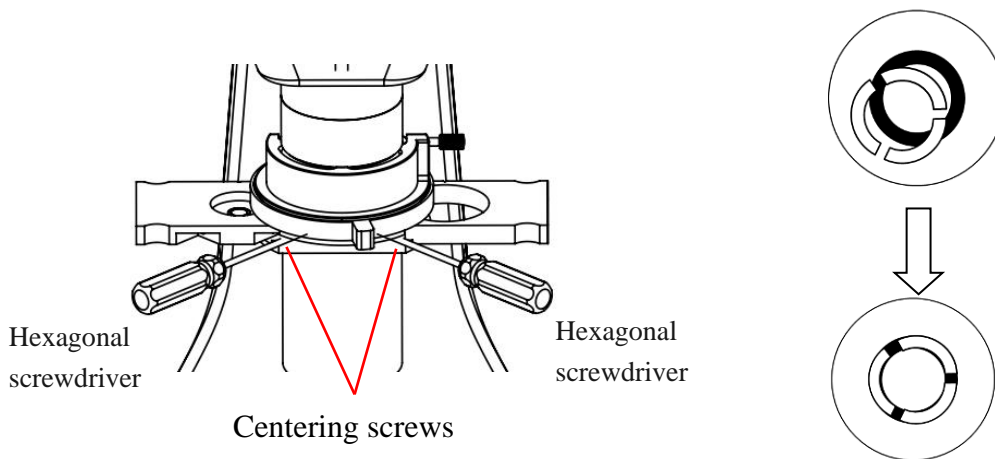

Decentering the phase ring and the PH annular diaphragm

Basically, the phase ring and the PH annular diaphragm should be adjusted so that they are concentric. However, slightly decentering them will produce a shadowing effect, resulting in a three-dimensional image.

3.10 Operation the Emboss Contrast Microscope

To perform emboss contrast microscopy, a condenser-side emboss contrast slider and eyepiece-tube-side emboss contrast slider must be mounted on the microscope.

3.10.1 Condenser-side emboss contrast slider

The condenser-side emboss contrast slider is equipped with a sector diaphragm. Attaching a centering telescope to the eyepiece tube enables you to view a sector diaphragm image.

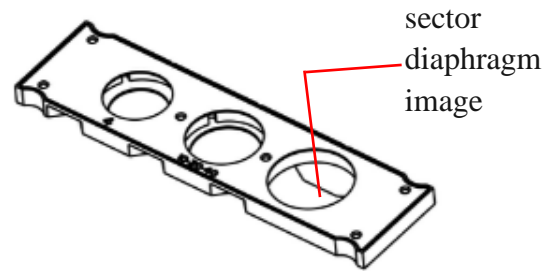

Insert the condenser-side emboss contrast slider into the condenser slider slot.

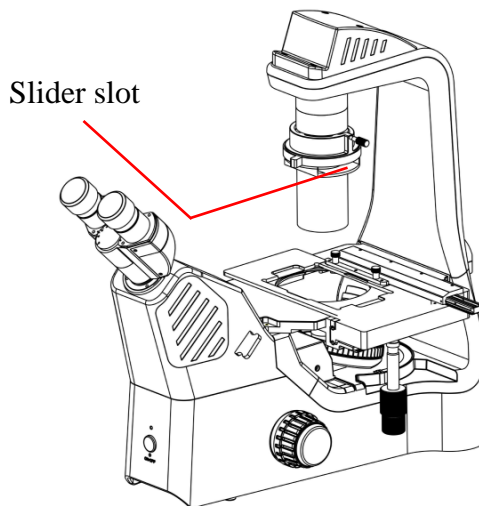

3.10.2 Eyepiece-tube-side Emboss Contrast Slider

The eyepiece-tube-side emboss contrast slider has position markings. For emboss contrast microscopy, insert the slider into the microscope until it reaches the position of the same number as the magnification of the objective. To switch back to bright-field microscopy, pull out the slider up to the hollow position.

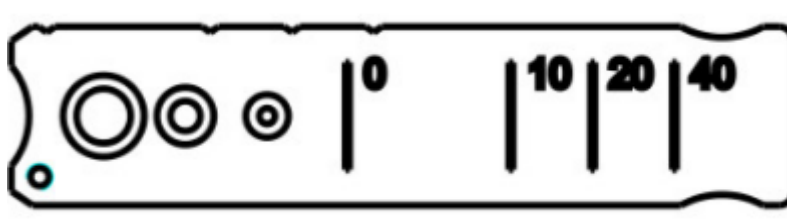

3.11 Operating the Episcopic Illumination Microscopy (for the BS-2094AF Only)

3.11.1 Episcopic illumination (for BS-2094AF)

As right figure shown, press the illumination switch to switch between episcopic illumination LED and diascopic illumination fluorescent LED mode.

Fluorescent LED illumination will turn weaker, when rotating direction of illumination brightness adjuster as right figure shown, whereas light source will turn brighter.

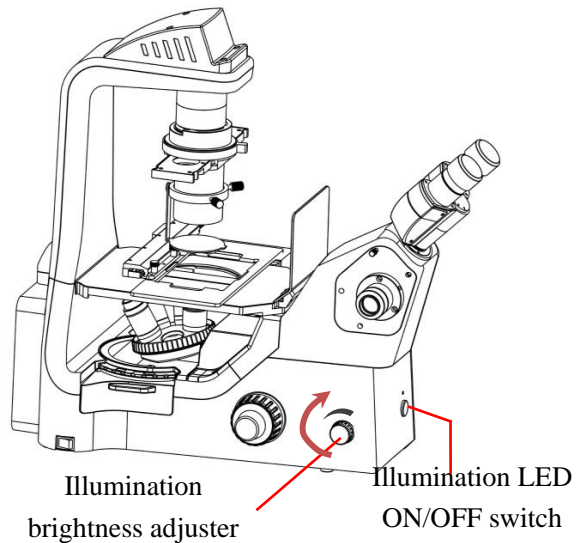

3.11.2 Fluorescence cube turret

The fluorescence cube turret reflects the illumination light from the fluorescence LED unit into the objective. This turret allows you to attach up to three filter cubes (each with a built-in dichroic mirror) and switch the filter cube by rotating the filter cube switching unit.

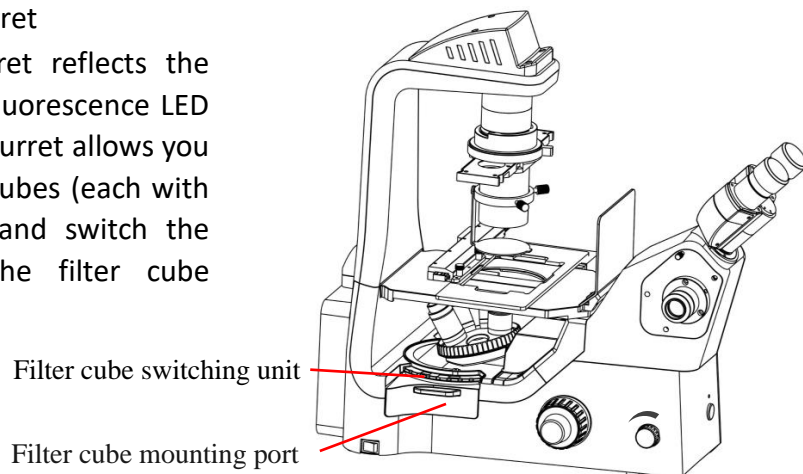

3.11.3 Filter cube switching unit

Rotating turret switches the filter cube. When the filter cube is switched, the fluorescence LED unit is switched automatically.

Fluorescent positions (1 to 3) and a bright-field position (☉) are allocated to the turret. The turret clicks each time a filter cube is brought to a fluorescent or a bright-field position. Position of the filter cube that is in the optical path is indicated on the right and left of the filter cube switching unit. When switching the filter cube, check the turret clicks and the position indications match the intended filter cube

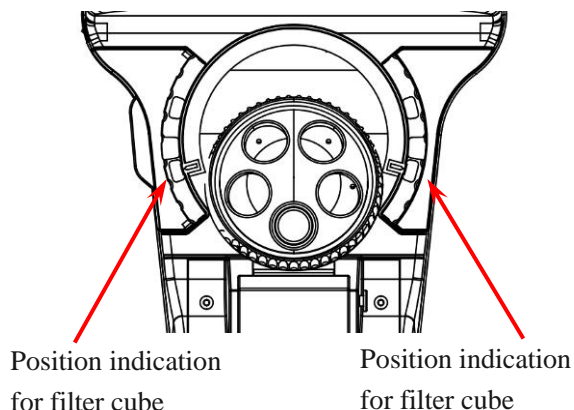

position, seen from the front of the microscope: If you select the bright-field position, the filter cube is removed from the optical path. The three bright-field positions have the same function. Rotate the turret so that the fluorescence positions indicated by the arrows on the left and right are the same (all points to “1” in the right figure), indicating that the filter cube has been switched into the optical path.

★ One-to-one corresponding relationship between filter cube sign, fluorescent LED light signs and filter cube should be paid attention to, when using. (see section 4.3.2 for the position of fluorescent LED lights)

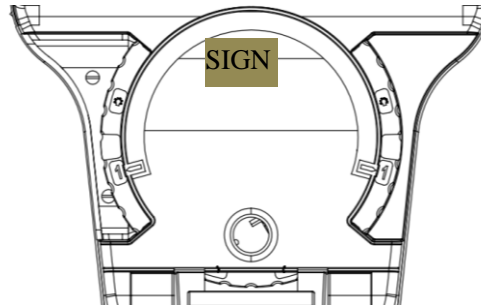

3.11.4 Fluorescence Filter Cube

A filter cube consists of three types of optical components: an excitation filter (BP filter), a barrier filter (BA filter), and a dichroic mirror (DM). Referring to the following items as a guide, select a desired combination of filter cubes according to the characteristics of the specimen and fluorophore.

- You can select a combination of an excitation filter and a barrier filter even if you are using the same excitation method.
- Excitation filters, barrier filters, and dichroic mirrors can be purchased separately.
- Excitation filters are exposed to strong light during operation and will deteriorate over time. Replace the filter as appropriate.

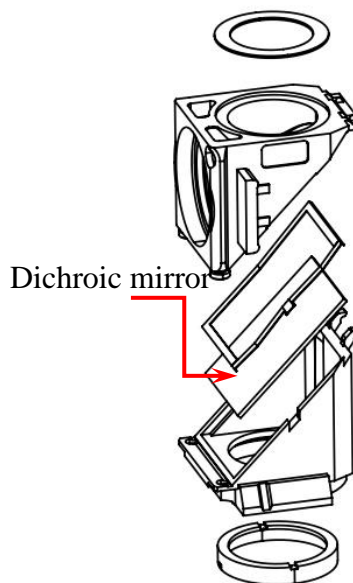

3.11.5 Fluorescent LED Unit

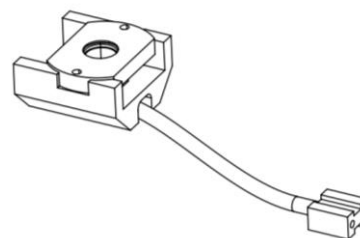

The BS-2094AF/BF allows you to mount up to three different fluorescence LED units as the light source for episcopic fluorescence microscopy.

When the fluorescence cube turret is rotated, the fluorescence LED unit is switched automatically. Therefore, mount the fluorescence LED unit at the same address as the filter cube to be used.

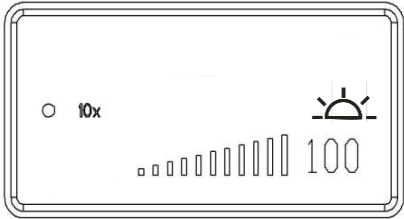

3.12 Operating the LCD (for BS-2094B series)

3.12.1 The status of LCD

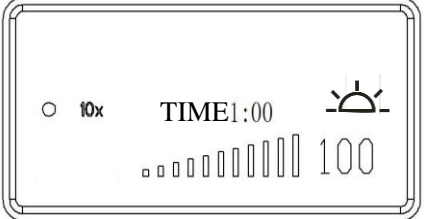
Start & working mode	Standby
	
Lock	Time setting
	

3.12.2 Operating the illumination switch

- **Click brightness adjuster:** becoming standby mode, it's "SLEEP" in the screen. Click again, it becomes working mode.
- **Press brightness adjuster three seconds:** setting time. First minute scale figures flash, then click the button, hour scale figures become flashing. When the time figures flash three times, it means setting successful.
- **Double-click:** locking brightness or unlocking. When it is locking, you can not adjust brightness every objective unless double click again.
- **Rotating:** changing brightness.
- **Press and rotating up meantime:** Transmitted illumination.
- **Pressing and rotating down meantime:** Fluorescent illumination.

4.1 Installation diagram

The order of installation of each component is shown in the following figure, and the digital indicate the installation step.

Save the supplied hexagonal spanner. You need it when you change parts.

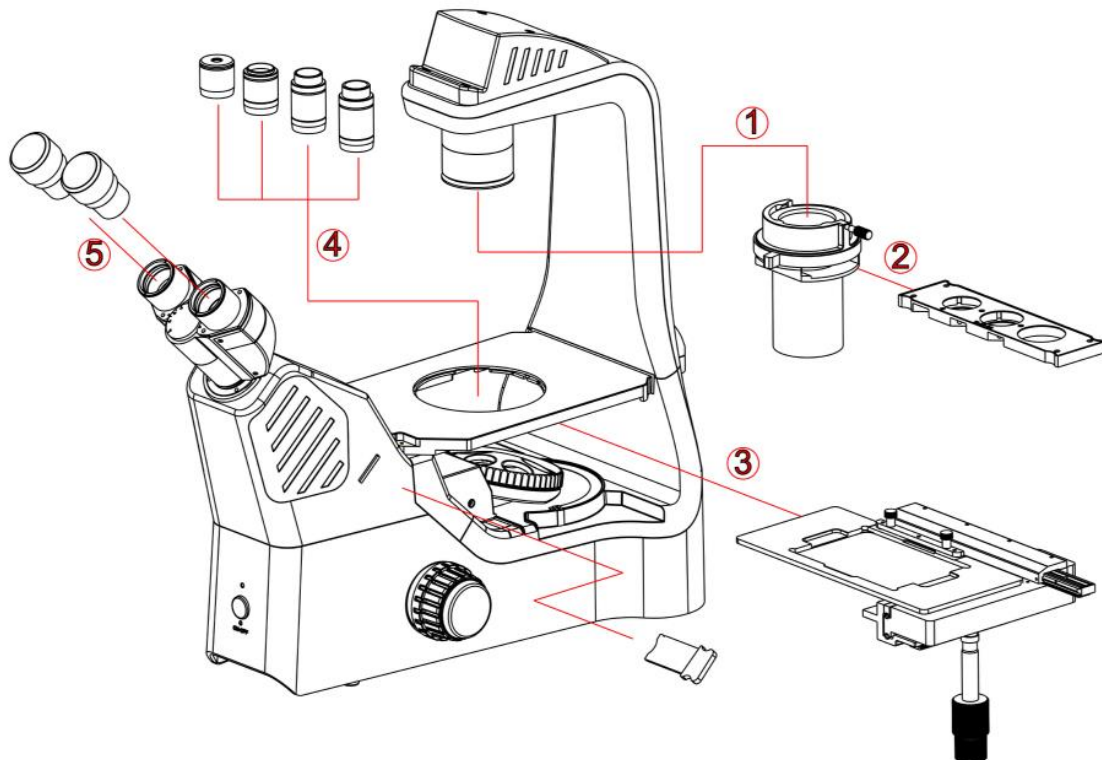

 CAUTION

Before installation, make sure all the parts are free of dust and dirt. Do not scratch any part or surface of the glass.

4.2 Installation Steps

BS-2094

4.2.1 Installing the Condenser

Unscrew the captive screws on the condenser a certain distance before aligning the tube with the dovetail groove of the condenser, then pushing lightly to the lowest position horizontally. and tighten the set screws.

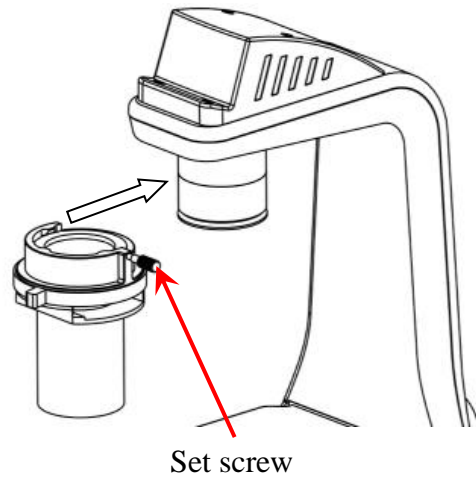

4.2.2 Installing the Phase Contrast Slider

With the sign facing up, push the phase contrast slider horizontally into the condenser socket, and notice the adjusting screw side of the phase contrast slider is facing the operator side.

Push into the process, when you hear the "click" sound, it indicates the phase contrast slider and the optical axis position are accurate.

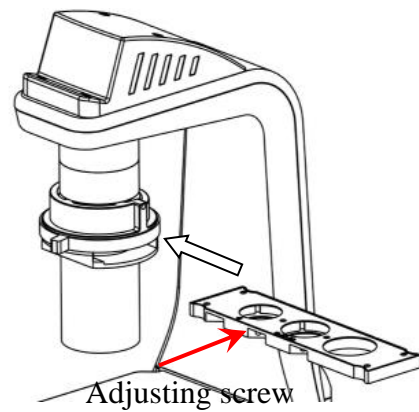

4.2.3 Installing the Moving Ruler

Install the moving ruler according to path 1 (as shown in the right figure). First, align the face A with tick mark of stage, then align the moving ruler with the side of the large stage surface, finally tighten the two set screws at the bottom.

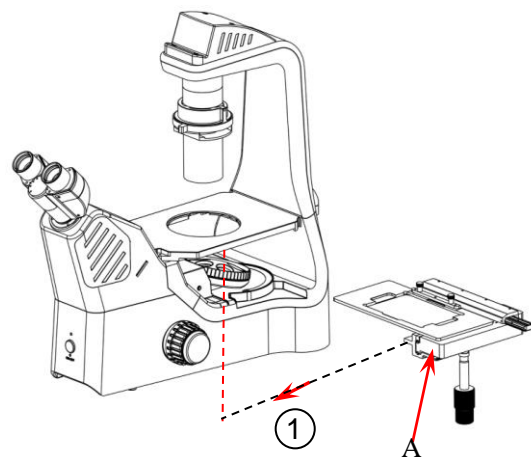

4.2.4 Installing the Objective

1. Adjust the coarse focus knob until the converter drops to low limit.
2. Screw the objectives with the lowest magnification to the converter from the left or right and then push the nosepiece clockwise to install the other objectives in descending order of magnification.

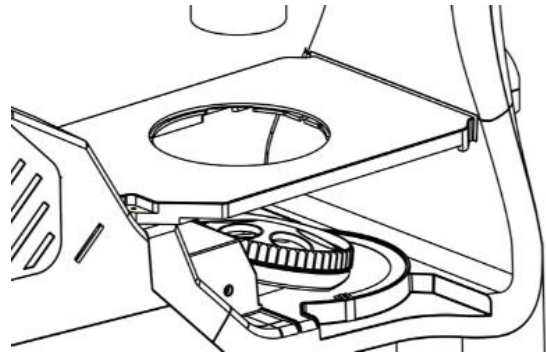

※ Installing the objective in this way makes it easy to change the magnification in the process.

★ Clean the objective regularly, because the objective is very sensitive to dust.

★ When operating, use 10× objective to search for samples and focus, and then need to switch to other magnification of the objective for observation.

★ When switching the objective, rotate the objective until it clicks to ensure that the desired objective enters the center of the optical path.

4.2.5 Installing the Eyepieces

Insert the eyepiece into the eyepiece tube until the back surface, as shown on the right figure.

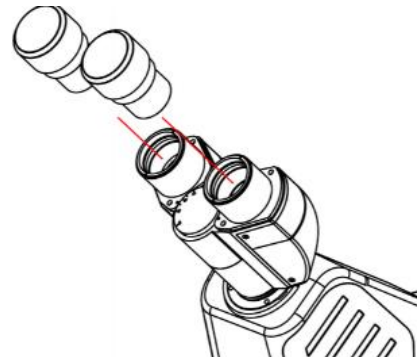

4.2.6 changing the LED Light Box

Press the right figure to open the light box cover first, then remove the plug of the LED lamp, and release the LED lights after releasing 3 fixed screws.

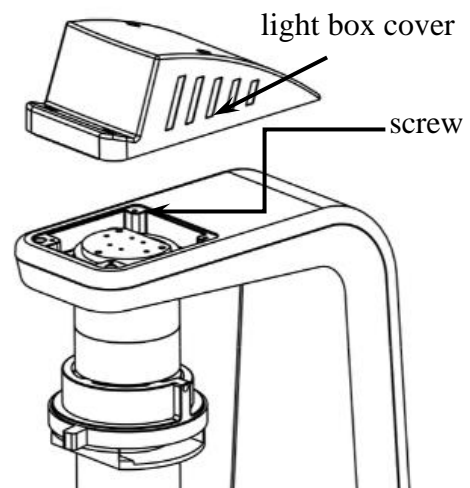

4.2.7 Installing the Camera

- 1) Remove dust cover from 1X relay lens(C-mount adapter).
- 2) Screw the camera into the relay lens as shown.

★ In the process of installing the camera, pay attention to one hand always hold the camera to prevent fall and break.

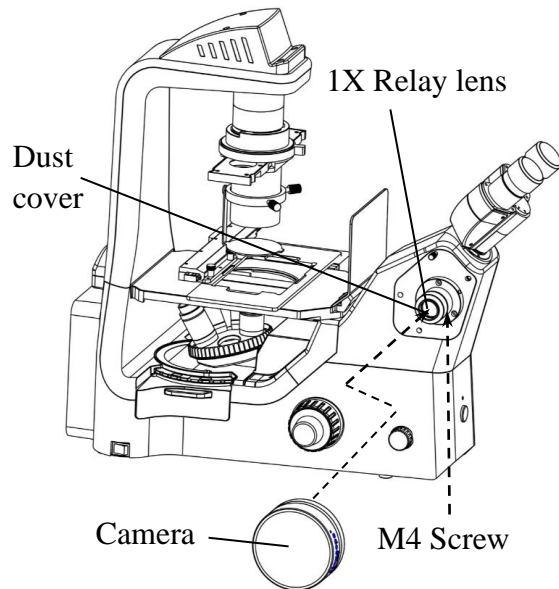

As shown on the right figure, there are two types of relay lenses to choose from

Relay lens magnification	Configuration
1.0×	Standard
0.5×	Optional

When replacing the relay lens, please turn out the camera, then unscrew the M4 screw and remove the relay lens part. Please refer to the installation of the above camera installation steps.

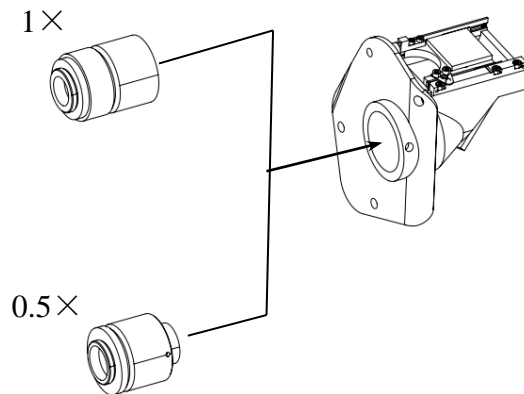

4.3 Assembly for Episcopic Illumination

BS-2094

4.3.1 Attaching the Filter Cube

- 1) Remove the cover from the filter cube mounting port.
- 2) Turn the turret to a position where a filter cube can be mounted easily.
- 3) Check the address on the turret, and align the filter cube with the guide groove before inserting.
- 4) Cover with cover.

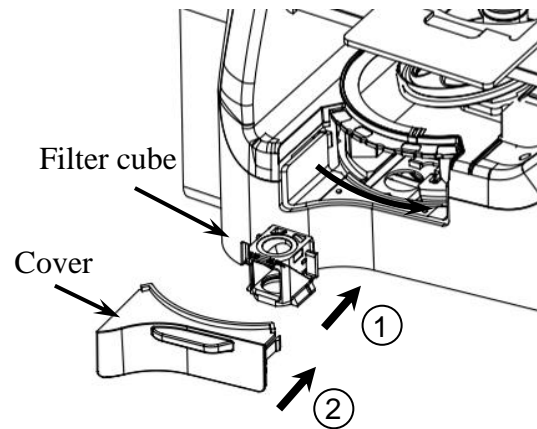

4.3.2 Installing the Fluorescence LED Unit

- 1) Loosen the four screws fixing the cover of the fluorescence LED unit on the back of the microscope, and remove the cover.
- 2) Mount the LED unit (corresponding to the desired wavelength) at the position that matches the address of the filter cube. The back cover of the LED unit is marked with position number. The corresponding position is as below:

Sign	LED light
1	G light
2	B light
3	U light

- 3) Remount the cover in the original position.

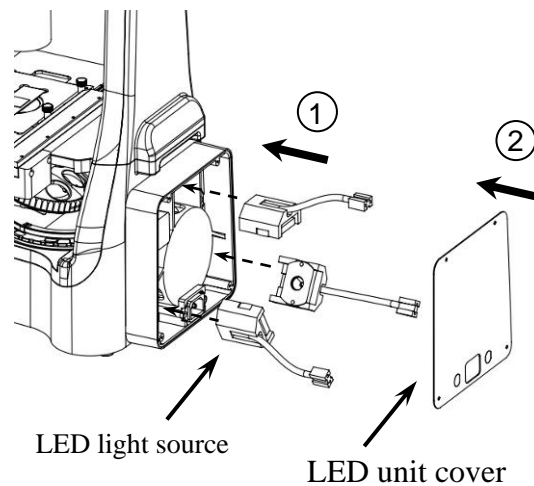

4.3.3 Replacing the Fuse

Open the cover, and in the fluorescence LED unit can see two pieces of fuse (as shown in the right figure), with a slotted screwdriver to counterclockwise unscrew the fuse.

★ The middle of the fuse is thin glass, please be careful when changing.

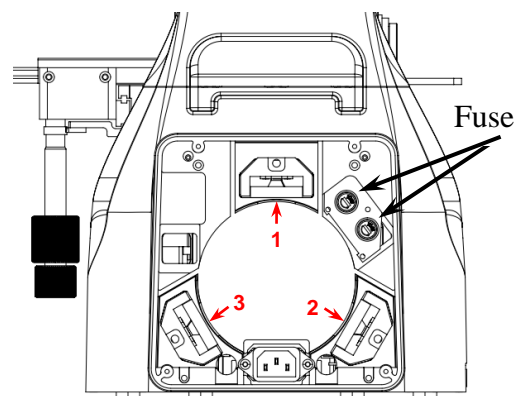

5.1 Cleaning

Clean or disinfect the lenses and other components according to the following instructions.

Cleaning tools

- Blower
- Soft brush
- Soft cotton cloth, lens cleaning tissue, gauze, etc.
- Absolute alcohol (ethyl alcohol or methyl alcohol), medical alcohol
- Petroleum benzene (only for wiping immersion oil)



CAUTION

- Petroleum benzene and absolute alcohol used for cleaning are highly flammable. Handle them with due care, and keep them away from fire or sparks and when turning the power switch on and off.
- When handling petroleum benzene or absolute alcohol, always follow the instructions provided by the manufacturer.
- Do not use organic solvents (such as alcohol, ether, and thinner) when cleaning painted, plastic, or printed parts of this product. Using organic solvents might result in discoloration or cause printed text to fade.
- Use petroleum benzene only when wiping off immersion oil from objectives. Do not use petroleum benzene to wipe the prism surface of the eyepiece tube or filters.

5.1.1 Cleaning the Lenses

Keep the lenses free of dust, fingerprints, and other dirt. Any dirt on lenses and filters will degrade the image. If the lenses become dirty, clean them according to the following procedure.

▲ Cleaning off minor dirt (such as dust)

- (1) Use a blower or similar tool to blow off dust.
- (2) If the above method does not work, dust off using a soft brush, or gently wipe off with a gauze.

▲ Cleaning off heavy dirt (such as fingerprints or oil stains)

Wipe off dirt using a soft clean cotton cloth, lens cleaning tissue, or gauze moistened with a small amount of absolute alcohol. (ethyl alcohol or methyl alcohol).



Tips for wiping

Do not wipe the lens surface using the same portion of a cloth or tissue more than once.

5.1.2 Cleaning Parts other than Lenses

▲ Cleaning off minor dirt (such as dust)

Wipe off using a silicone cloth.

▲ Cleaning off heavy dirt (such as fingerprints or oil stains)

Gently wipe off using a gauze moistened with a small amount of a diluted neutral detergent solution.

5.1.3 Cleaning off Immersion Oil

- (1) Wipe off using petroleum benzene.
- (2) Then, wipe off using absolute alcohol (ethyl alcohol or methyl alcohol) for a better finish.

☑ If petroleum benzene is unavailable

If petroleum benzene is unavailable, use methyl alcohol. Note that methyl alcohol is less effective, and requires more wipes.

5.1.4 Decontaminating this product

We recommend use 70% medical alcohol for normal disinfection of the microscope. Using organic solvents might result in discoloration of the plastic parts.

☑ Caution on disposal

If a sample comes into contact with this product, check the sample is hazardous or not. If the sample is hazardous, follow the standard procedure of your laboratory.

5.2 Storage

- Store this product in a place that is low in humidity, and therefore less prone to mold.
- Store this product in a temperature range of -20 to +60°C and a relative humidity of up to 90% (no condensation).
- Store objectives and eyepieces in a desiccator or other vessel that contains a desiccant.
- Put a dust cover over this product to protect it from dust.
- Do not cover this product unless the power switch on the main body of the microscope has been turned off (set to "O"), and the lamp house allowed to sufficiently cool. (Cooling takes approximately 30 minutes.)

6.1 Optical System

TROUBLE	CAUSE	SOLUTION
The edge of the field of view is dark or the brightness is not uniform	The nosepiece is not in the located position (objective and light path not coaxial)	Locate the nosepiece properly where it clicks
	A lens (the objective, condenser, eyepiece or collector) is dirty.	Clean it thoroughly
Dirt or dust is visible in the field of view	A lens (the objective, condenser, eyepiece or collector) is dirty.	Clean it
	Dirt/dust on the specimen	Clean it
	Specimen is placed reversely	Turn it over
	A lens (the objective, condenser, eyepiece or collector) is dirty.	Clean it
	The aperture diaphragm is too large	Appropriate down
	Dirt or dust on the eyepiece	Clean it
	The aperture diaphragm is too small	Appropriate up
One side of image is blurred	Condenser is not properly centered	Center the condenser with the centering screw
	The nosepiece is not properly engaged	Engage the nosepiece properly
	The specimen is not clamped	Clamp it with stage clips
The image moves while focusing on the zoom	Specimens float on the surface of the platform	placed it stably
	The nosepiece is not properly engaged	Engage the nosepiece properly
The brightness is not enough	The aperture diaphragm is too small	Appropriate up

6.2 Mechanical System

TROUBLE	CAUSE	SOLUTION
image cannot focus with the high-power objective	Specimen is placed reversely; Cover slip is too thick	Turn it over; Use standard cover glass with thickness of 0.17mm
The objective will touch the Specimen when it is converted from low to high	Specimen is placed reversely; Cover slip is too thick	Turn it over; Use standard cover glass with thickness of 0.17mm
The specimen did not move smoothly	The specimen holder is not securely fastened	Make sure it is securely fastened
Field of view of one eye does not match that of the other	Interpupillary distance is incorrect	Adjust interpupillary distance
eyestrain	the Interpupillary Distance does not adjust	Adjust the Interpupillary Distance correctly
	the illumination is not appropriate	Adjust illumination switch

6.3 Electrical System

TROUBLE	CAUSE	SOLUTION
The bulb cannot light	No power supply	Check the power cord connection
	The pin of the bulb doesn't insert properly	Insert the pin deeply
	The bulb broken	Replace with a new one
The bulb burns out suddenly	The bulb is not the specified one; The voltage is too high	Use the specified bulb; lower the voltage
the illumination is not bright enough	The bulb is not the specified one	Use the specified bulb
	The voltage is too low	Raise the voltage
ECO does not work	There are other things in front of the device	move things away from the device
Can't open the camera	The driver is installed correctly or not	Install the driver correctly
	The USB line is not normal	Check the USB line and connect it again

After-sales service:

Within 36 months from the date of delivery, we will provide free warranty and replacement parts for the microscope which can not work because of product quality problem, in the absence of human factors.

We provide a lifetime maintenance of the microscope, and provide a price discount for long term out of warranty.

Contact information:**BestScope International Limited**

Add: 4#811, No.26 Financial Street, Shi Jing Shan District, Beijing, China

Tel: +86 10 88747221

E-mail: info@bestscope.net

Http: www.bestscope.net