

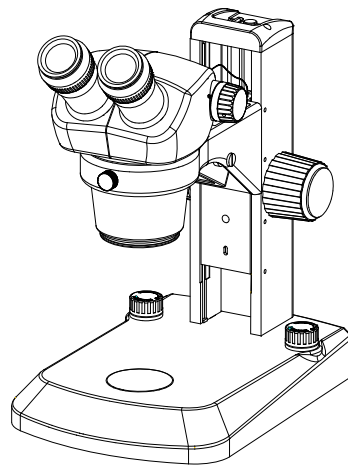

BS-3020 Stereo Microscope

User Manual



It is recommended strongly that you study this manual thoroughly before using the microscope. Retain this manual in an easily accessible place near the work desk for future reference.

CONTENT

USER NOTICE.....	2
1. Components.....	4
2. Assembly.....	5
2.1 Assembly Diagram.....	5
2.2 Detailed Assembly Procedure.....	6
3. Adjustment and Operation.....	8
3.1 Adjusting Binocular Viewing Head.....	8
3.2 Focus Adjustment.....	9
4. Specification.....	10
5. Troubleshooting.....	10
6. Outfit.....	11

USER NOTICE

1. Safety Precaution

1. Carefully open the box, avoid the accessories, like lens, dropping to ground and being damaged.
2. Check the input voltage, be sure the input voltage which signed on the microscope is consistent with the power supply voltage, or it will bring a serious damage to the instrument.
3. Do keep the instrument out of direct sunlight, high temperature or humidity, dusty and easy shaking environment. Make sure the stage is smooth, horizontal and firm enough.
4. To prevent the microscope body from turning over, its pivot angle must be limited to 30°.
5. A microscope is a precision instrument. Handle it with care and avoid subjecting it to sudden or severe impact.
6. Make sure the instrument is earthed, to avoid lighting strike.
7. Do not disassemble any part of the microscope, especially the electrical parts on the bottom side as this may result in electric shock.
8. Use the factory supplied power cord, please.

2. Maintenance and Storage

1. All the lenses have been well checked and adjusted. It is forbidden to disassemble them yourself.
2. The binocular viewing head and focusing unit have a compact and precise frame; please don't disassemble them as possibly as you can.
3. Keep the instrument clean, wipe dust regularly, and be attention to avoid contaminating the optical elements especially.
4. The contaminations on the prism, as fingerprint and oil, could be gently wiped with a piece of soft cloth or tissue paper, gauze which has been immersed in pure alcohol or ether. **(Note that the alcohol and ether are highly flammable, do keep them away from the fire or potential sources of electrical sparks, and use them in a drafty room as possible as you can.)**
5. Do not attempt to use organic solvents to clean the microscope components other than the glass components. To clean them, use a lint-free, soft cloth slightly moistened with a diluted neutral detergent.
6. If the microscope is splashed by liquid during using, cut off the power at once, and wipe up the moisture.
7. Do not disassemble any parts of the microscope, which will affect the function or decline the performance of the microscope.
8. Place the instrument in a cool, dry position. When not using the microscope, keep it covered with a dust cover.

1. Components

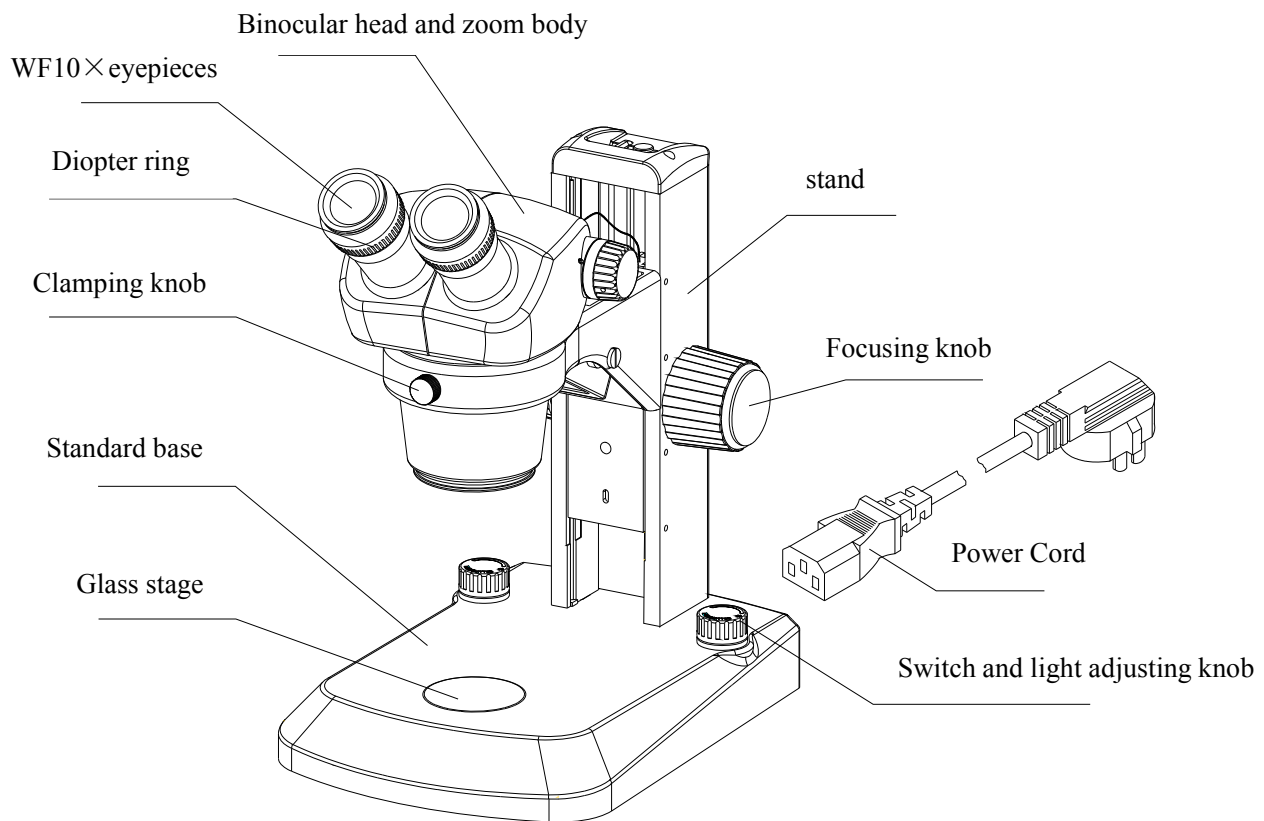

Stereo Microscope BS-3020B

2. Assembly

2.1 Assembly Diagram

The diagram below shows how to assemble the various modules. The numbers indicate the order of assembly.

★When assembling the microscope, make sure that all parts are free of dust and dirt, and avoid scratching any parts or touching glass surfaces.

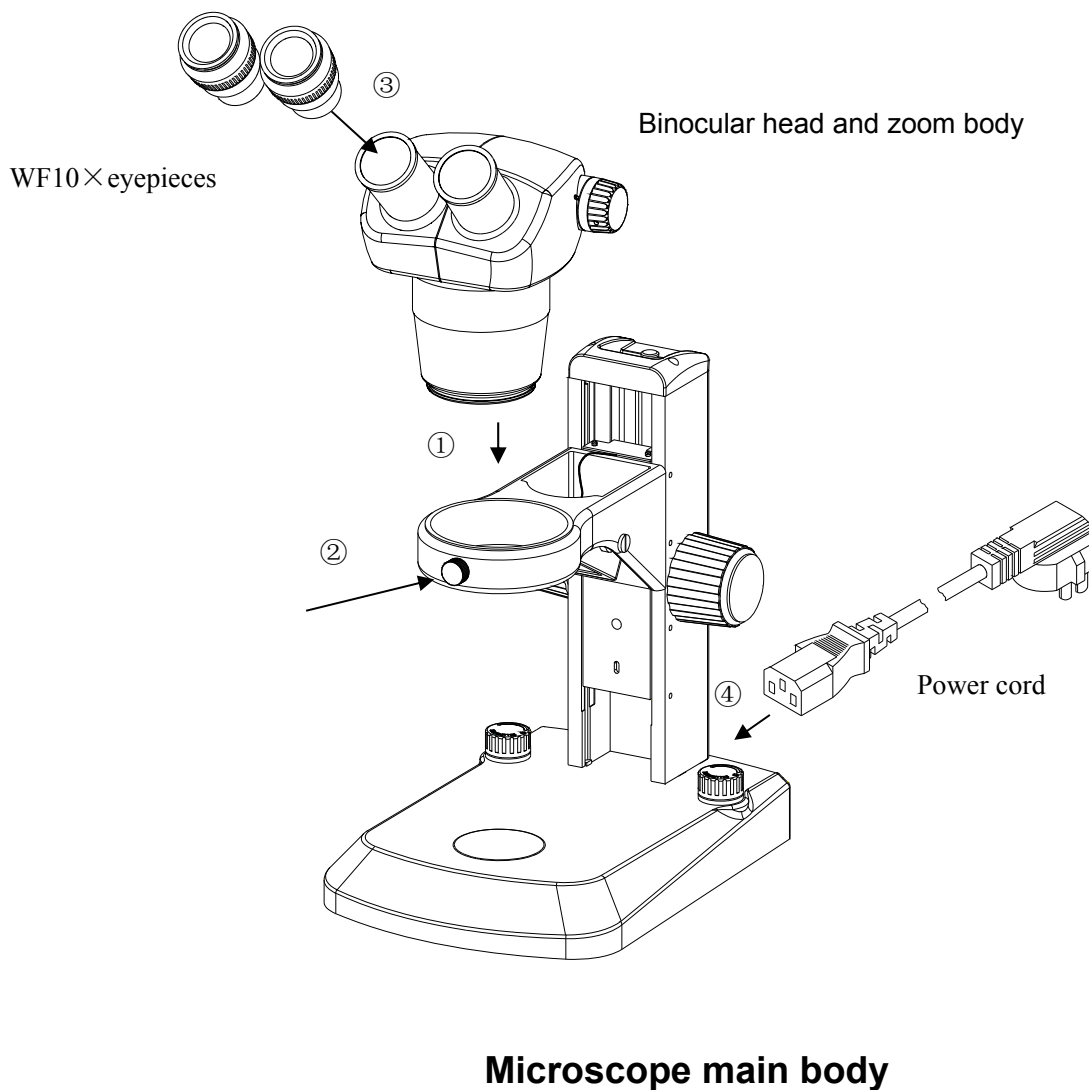

2.2 Detailed Assembly Procedure

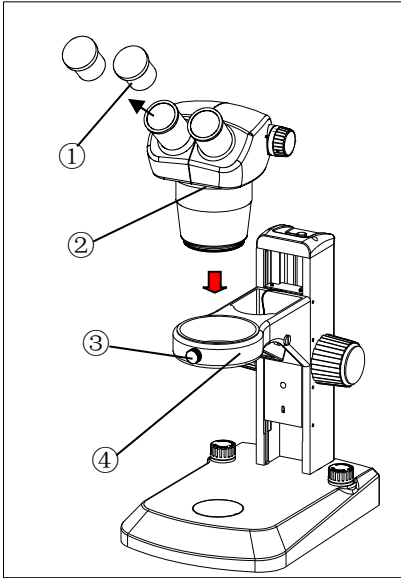

Fig. 1

2.2.1 Mounting binocular head (Fig.1)

Loose the clamping bolt③ on the pillar④ and insert the binocular head and zoom body assembly②into the bracket of the pillar, then screw down the bolt③.

2.2.2 Mounting eyepieces (Fig.1, Fig.2, Fig.3)

Remove the eyepiece dust caps① and gently insert two adjustable eyepieces ⑤ into the eyepiece sleeves until they stops, as in Fig.3.

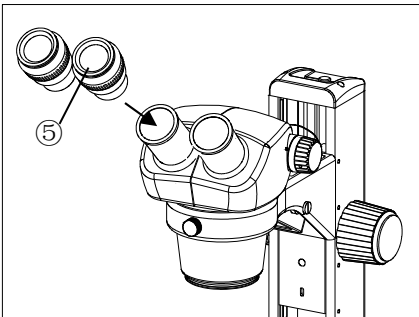

Fig. 2

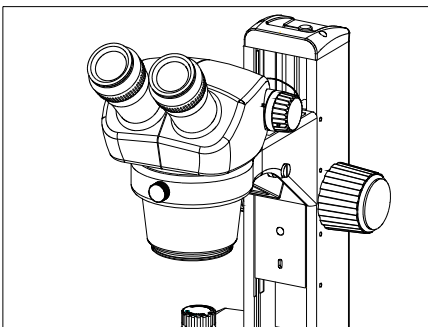

Fig. 3

Note:

Working Environment Requirement:

1. Ambient temperature: 5 ° C to 40 ° C (41 ° F to 104 ° F), Maximum R.H: 85%.
2. High Temperature will result in a mildewing, dew and even ruinous instrument.
3. Avoid placing the instrument in a dusty environment. When ending your microscope operation, please cover it with the dust cover.
4. Lay the microscope in a plan and stable position, please.

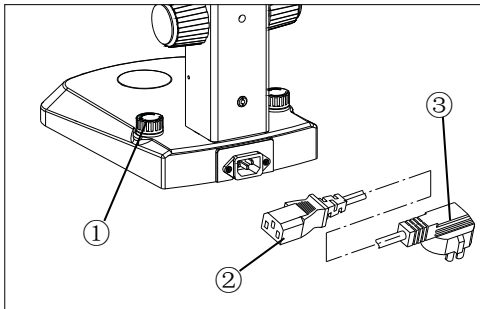

Fig. 4

2.2.3 Connecting the power cord (Fig.4)

1. Clockwise rotate the left and right brightness adjusting switches① until the end on (off) state before connecting the power cord②.
2. Insert the power plug② into the power jack of the microscope; make sure the connection is well.
3. Plug the power cord③ into the power supply receptacle safely. Make sure the connection is well.

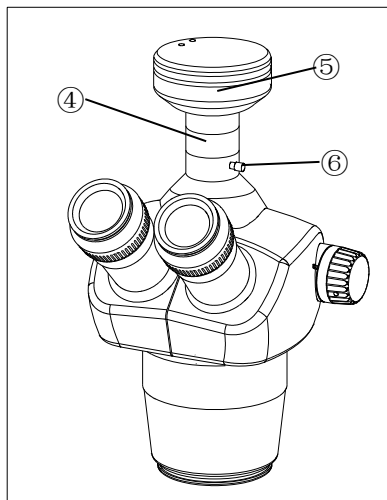

Fig. 5

- Adjustable illumination for both LEDs (top and bottom).
- Input Rating: 100V~240V.

Trinocular head is optional if video or photography function is needed.

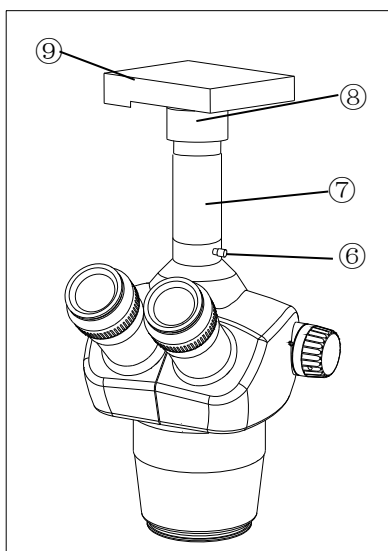

Fig. 6

2.2.4 Video(Photography) accessories assembly

1. Installing the video set: Remove the dust cap of the trinocular viewing tube, revolve the camera set ⑤ into the screw thread end---the video adapter④ with C mount, and insert the other end into the tri-through port and screw down the bolt⑥.
2. Installing the photography set: Remove the dust cap of the trinocular viewing tube, install the photography accessories⑦ into the tri-through port, and screw down the locking bolts⑥, change the camera⑨ gun with digital photography adapter⑧, and insert the adapter into the accessories, as in Fig 6.

3. Adjustment and Operation

3.1 Adjusting Binocular Viewing Head

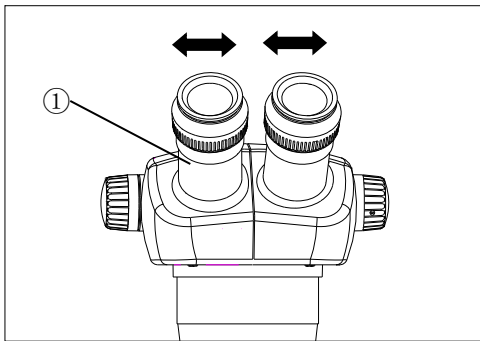

Fig. 7

3.1.1 Adjusting interpupillary distance (Fig.7)

Different users have different interpupillary distances. So when users change, do the interpupillary distance adjustment.

While looking through the eyepieces, hold the left and right of the binocular assembly ① and adjust the eyepieces by opening or closing them for binocular vision until the left and right fields of view coincide completely.

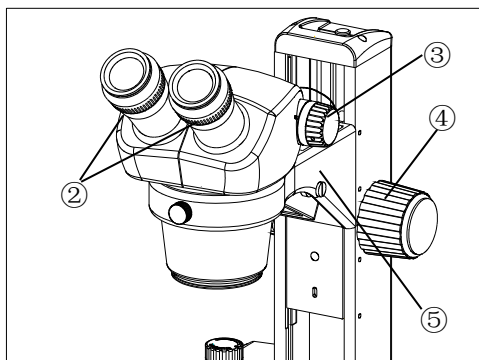

Fig. 8

3.1.2 Adjusting diopter ring (Fig.8)

- 1 . Set the diopter rings of both eyepieces to "0" position. (Do this when users change, because different users have different diopters.)
- 2 . Place an easy-to-observe specimen on the stage plate.
- 3 . Rotate the zoom body knob ③ to the highest magnification 4.5 \times , and turn the focusing knob ④ to focus the specimen.
- 4 . Rotate the zoom body knob ③ to the lowest magnification 0.7 \times , looking only into the left eyepiece, adjust the diopter ring on left eyepiece to focus the specimen. Then do the same thing for the right one.
- 5 . Repeat item 3 and 4 until the specimen image can always focus without any adverse effect of the changes of magnification on the definition of the image.

- The working distance of the microscope is 97mm, the binocular head bracket ⑤ could be mounted onto the higher or lower position according to your needing. Remove the clamping bolt with provided hexagonal driver and move the bracket ⑤ down to the lower position and set it with original bolt (Fig.8).

3. 2 Focus Adjustment

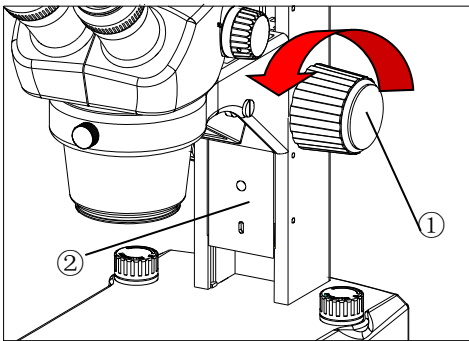

Fig. 9

3.2.1 Adjusting the rotation tension of the focus adjustment knob (Fig.9, Fig.10)

1. Rotate the focus adjustment knob① to move the slider② to a lower place for fear that the zoom body drops down suddenly if the tension is decreased too much.
2. Hold the focus adjustment knobs① with both hands, stop the left knob and rotate the right knob to increase or decrease the focus knob tension.
3. Rotate two sides of the adjustment knobs in the same direction (otherwise it will get loose) to move the zoom body up and down to focus on the specimen.

3.2.2 Changing the magnification

1. The zooming knots located at two sides of the zooming body could change the magnification of the specimen image.
2. Total Magnification = Magnification of zoom body × magnification of eyepiece

Note: While using the auxiliary objective, it should be multiplied by its magnification in addition .

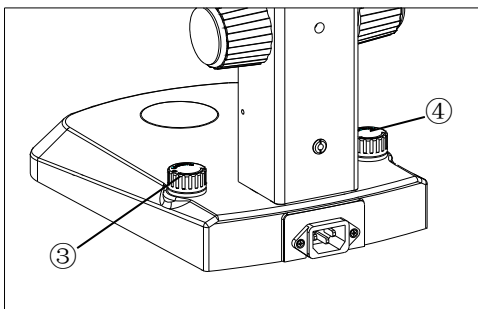

Fig. 10

3.3 Illumination

1. Adjustable illumination for both LEDs (top and bottom).
2. Brightness adjustment: the right brightness adjustment knob③ is used to adjust the bottom illumination, and the left brightness adjustment knob④ is used to adjust the top illumination. Each knob have its own on-off. Rotate anticlockwise to open the power, and continue would increase the brightness, keeping rotating clockwise would decrease the brightness until it is power off.

4. Specification

4.1 Zoom ratio:1:4.5

4.2 Objective magnification: 1×~4.5×

4.3 Binocular viewing head: Inclined at 45, interpupillary distance range: 55~75mm

4.4 Working distance: 97mm

4.5 Illumination system: Adjustable illumination for both LEDs (top and bottom)

Auxiliary objective	Working distance (mm)	Eyepiece					
		10× Field of view 20		15× Field of view 16		20× Field of view 12	
		Magnification	Actual field	Magnification	Actual field	Magnification	Actual field
No	97	10-45×	Φ20-Φ4.4	15-67.5×	Φ16-Φ3.56	20-90×	Φ12-Φ2.67
0.75×	120	7.5-33.75×	Φ26.7-Φ5.9	11.25-50.625×	Φ21.3-Φ4.74	15-67.5×	Φ16-Φ3.56
2×	30	20-90×	Φ10-Φ2.2	30-135×	Φ8-Φ1.78	40-180×	Φ6-Φ1.33

5. Troubleshooting

Under certain conditions, performance of this unit may be adversely affected by factors other than defects. If a problem occurs, please review the following list and take remedial action as needed. If you cannot solve the problem after checking the entire list, please contact your local franchiser for assistance.

PROBLEM	CAUSE	SOLUTION	PAGE
1. Incomplete binocular vision.	Interpupillary distance is not correctly adjusted.	Adjust it correctly	8
	Diopter adjustment is incomplete.	Complete diopter adjustment	
2. Dirt is visible in field of view	Dirt on specimen	Clean specimen	3
	Dirt on eyepiece	Clean eyepiece	
3. The visibility of the image is poor.	Dust on objective front lens.	Clean lens surface	
4. Specimen image blurs when zoom magnification is changed.	Diopter ring is not correctly adjusted.	Adjust it correctly.	8
	Not in complete focus on specimen.	Focus specimen correctly at a high magnification.	

5. Coarse focus adjustment knobs rotate with too much resistance.	Tension adjustment ring is too tight.	Loosen it properly.	9
6. Zoom microscope body drops or specimen goes out of focus during observation.	Tension adjustment ring is too loose.	Tighten it properly.	9

7. Outfit

Components	Specification	Quantity	BS-3020B
Main body	Main body	1	●
Observation system	Binocular head and zoom body	1: 4.3	○
		1: 4.5	●
	Trinocular head and zoom body	1	○
Illuminator	Transmitted illuminator (LED)	1	●
	Reflected illuminator (LED)	1	●
Eyepiece	10×Eyepiece	2	●
	15×Eyepiece	2	○
	20×Eyepiece	2	○
Auxiliary objective	0.75×objective	1	○
	2×objective	1	○
digital camera		1	○
camera adapter		1	○
Stage plate	Glass plate	1	●
Power cord	Power cord	1	●

●: standard Outfit; ○: Optional