

## BS-6025 Research Upright Metallurgical Microscope



BS-6025TRF

### Introduction

BS-6025 series upright metallurgical microscopes have been developed for research with a number of pioneering design in appearance and functions, with wide field of view, high definition and bright/dark field semi-apochromatic metallurgical objectives and ergonomical operating system, they are born to provide a perfect research solution and develop a new pattern of industrial field. The objectives could be motorized controlled by the buttons on the microscope front base, the illumination intensity will change after changing objective.

### Features

#### 1. Excellent Infinite Optical System.

With the excellent infinite optical system, BS-6025 series upright metallurgical microscope provides high resolution, high definition and chromatic aberration corrected images which could display the details of your specimen very well.

#### 2. Modular Design.

BS-6025 series microscopes have been designed with modularity to meet various industrial and material science applications. It gives users flexibility to build a system for specific needs.

### 3. Convenient Control.



#### (1) Motorized Objective Switch and ECO function.

Objectives could be switched by simply pressing the rotating buttons. Users could also self-define two of the most commonly used objectives and switch between these two objectives by pressing the green button. The light intensity will be automatically adjusted after you change the objective.

The microscope light will be off automatically after 15 minutes from operators leaving. It not only saves energy, but also saves the lamp lifetime.



#### (2) Shortcut Buttons.

With this shortcut button, the user could switch 2 pre-set objectives fast. This shortcut button also could be set with other functions by users.

### 4. Comfortable and Easy to Use.



#### (1) NIS45 Infinite Plan Semi-APO and APO Objectives.

With high transparent glass and advanced coating technology, NIS45 objective lens can provide high resolution images and accurately reproduce the natural color of the specimens. For special applications, a variety of objectives is available, including polarizing and long working distance.



#### (2) Nomarski DIC.

With newly designed DIC module, the height difference of a specimen which can not be detected with brightfield becomes a relief-like or 3D image. It is ideal for the observation of LCD conducting particles and the surface scratches of hard-disk etc.



**(3) Focusing System.**

In order to make the system suitable for the operating habits of the operators, the knob of focusing and stage can be adjusted to the left-hand side or right-hand side. This design makes the operation more comfortable.



**(4) Ergo Tilting Trinocular Head.**

Eyepiece tube can be adjustable from 0 ° to 35 ° , Trinocular tube can be connected to DSLR camera and digital camera, having a 3-position beam splitter (0:100, 100:0, 80:20), the splitter bar can be assembled on the either side according to user's requirement.

**5. Various Observation Methods.**

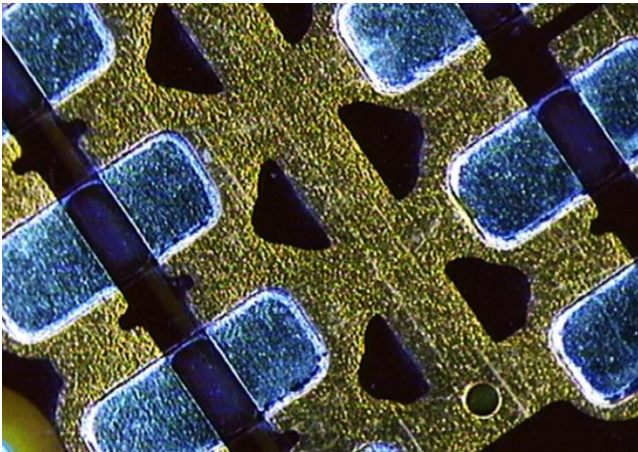

**Darkfield (Wafer)**

Darkfield enables the observation of scattered or diffracted light from the specimen. Anything that is not flat reflects this light while anything that is flat appears dark so imperfections clearly stand out. The user can identify the existence of even a minute scratch or flaw down to the 8nm level-smaller than the resolving power limit of an optical microscope. Darkfield is ideal for detecting minute scratches or flaws on a specimen and examining mirror surface specimens, including wafers.



**Differential Interference Contrast (Conducting Particles)**

DIC is a microscopic observation technique in which the height difference of a specimen not detectable with brightfield becomes a relief-like or three-dimensional image with improved contrast. This technique utilizes polarized light and can be customized with a choice of three specially designed prisms. It is ideal for examining specimens with very minute height differences, including metallurgical structures, minerals, magnetic heads, hard-disk media and polished wafer surfaces.

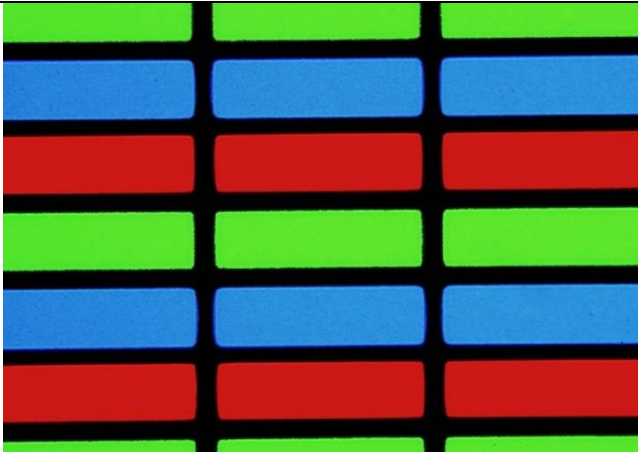

**Transmitted Light Observation (LCD)**

For transparent specimen such as LCDs, plastics, and glass materials, transmitted light observation is available by using a variety of condensers. Examining specimen in transmitted brightfield and polarized light can be accomplished all in one convenient system.

**Polarized Light (Asbestos)**

This microscopic observation technique utilizes polarized light generated by a set of filters (analyzer and polarizer). The characteristics of the sample directly affect the intensity of the light reflected through the system. It is suitable for metallurgical structures (i.e., growth pattern of graphite on nodular casting iron), minerals, LCDs and semiconductor materials.

**Application**

BS-6025 series microscopes are widely used in institutes and laboratories to observe and identify the structure of various metal and alloy, it also can be used in electronics, chemical and semiconductor industry, such as wafer, ceramics, integrated circuits, electronic chips, printed circuit boards, LCD panels, film, powder, toner, wire, fibers, plated coatings, other non-metallic materials and so on.

**Specification**

Item	Specification	BS-6025RF	BS-6025TRF	
Optical System	NIS45 Infinite Color Corrected Optical System (Tube length: 180mm)	●	●	
Viewing Head	Ergo Tilting Trinocular Head, adjustable 0-35° inclined, interpupillary distance 47mm-78mm; splitting ratio Eyepiece:Trinocular=100:0 or 20:80 or 0:100	●	●	
	Seidentopf Trinocular Head, 30° inclined, interpupillary distance: 47mm-78mm; splitting ratio Eyepiece:Trinocular=100:0 or 20:80 or 0:100	○	○	
	Seidentopf Binocular Head, 30° inclined, interpupillary distance: 47mm-78mm	○	○	
Eyepiece	Super wide field plan eyepiece SW10X/25mm, diopter adjustable	●	●	
	Super wide field plan eyepiece SW10X/22mm, diopter adjustable	○	○	
	Extra wide field plan eyepiece EW12.5X/16mm, diopter adjustable	○	○	
	Wide field plan eyepiece WF15X/16mm, diopter adjustable	○	○	
	Wide field plan eyepiece WF20X/12mm, diopter adjustable	○	○	
Objective	NIS45 Infinite LWD Plan Semi-			
	APO Objective (BF & DF)	5X/NA=0.15, WD=20mm	●	●
		10X/NA=0.3, WD=11mm	●	●

		20X/NA=0.45, WD=3.0mm	●	●
	NIS45 Infinite LWD Plan APO Objective (BF & DF)	50X/NA=0.8, WD=1.0mm	●	●
		100X/NA=0.9, WD=1.0mm	●	●
Nosepiece	Backward Motorized Sextuple Nosepiece (with DIC slot)		●	●
Condenser	LWD condenser N.A.0.65		○	●
Transmitted Illumination	12V/100W halogen lamp, Kohler illumination, with ND6/ND25 filter		○	●
	3W S-LED lamp, center pre-set, intensity adjustable		○	○
Reflected Illumination	Reflected light 12W/100W halogen lamp, Koehler illumination, with 6 position turret		●	●
	100W halogen lamp house		●	●
	BF1 bright field module		○	○
	BF2 bright field module		●	●
	DF dark field module		●	●
	Built-in ND6, ND25 filter and color correction filter		○	○
ECO Function	ECO function with ECO button		●	●
Motorized Control	Nosepiece control panel with buttons. 2 of the most commonly used objectives could be set and switch by pressing the green button. The light intensity will be automatically adjusted after changing the objective		●	●
Focusing	Low-position coaxial coarse and fine focusing, fine division 1μm, Moving range 35mm		●	●
Max. Specimen Height	76mm		●	
	56mm			●
Stage	Double layers mechanical stage, size 210mmX170mm; moving range 105mmX105mm (Right or left handle); precision: 1mm; with hard oxidized surface to prevent abrasion, Y direction could be locked		●	●
	Wafer holder: could be used to hold 2", 3", 4" wafer		○	○
DIC Kit	DIC Kit for reflected illumination (can be used for 10X, 20X, 50X, 100X objectives)		○	○
Polarizing Kit	Polarizer for reflected illumination		○	○
	Analyzer for reflected illumination, 0-360° rotatable		○	○
	Polarizer for transmitted illumination			○
	Analyzer for transmitted illumination			○
Other Accessories	0.5X C-mount Adapter		○	○
	1X C-mount Adapter		○	○
	Dust Cover		●	●
	Power Cord		●	●
	Calibration slide 0.01mm		○	○
	Specimen Presser		○	○

Note: ● Standard Outfit, ○ Optional

### System Diagram

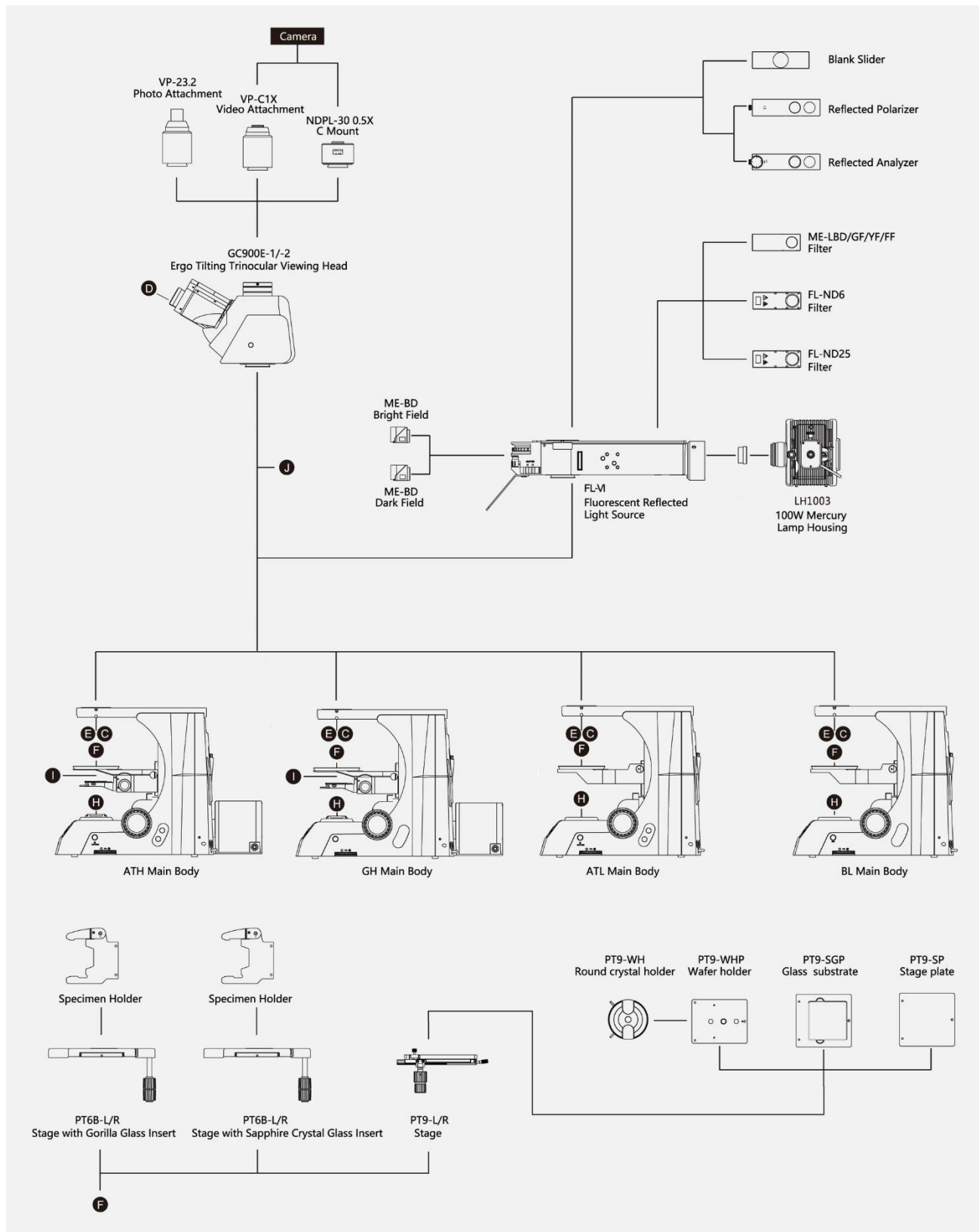

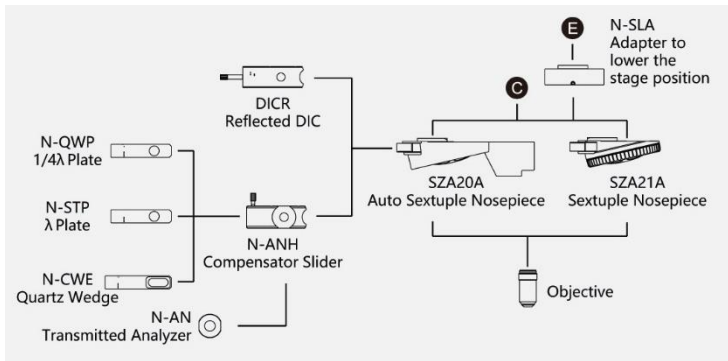
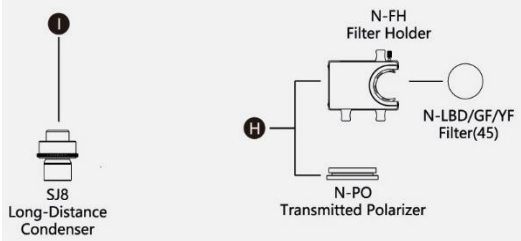
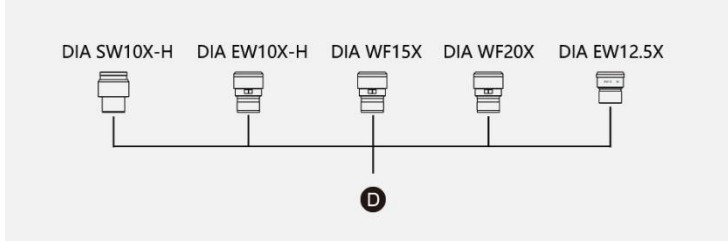

**Dimension**

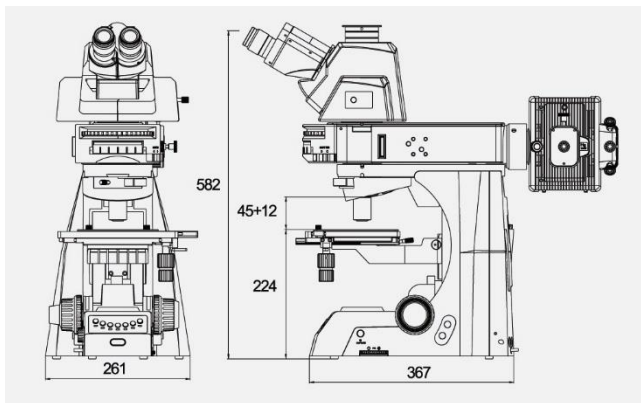

BS-6025RF

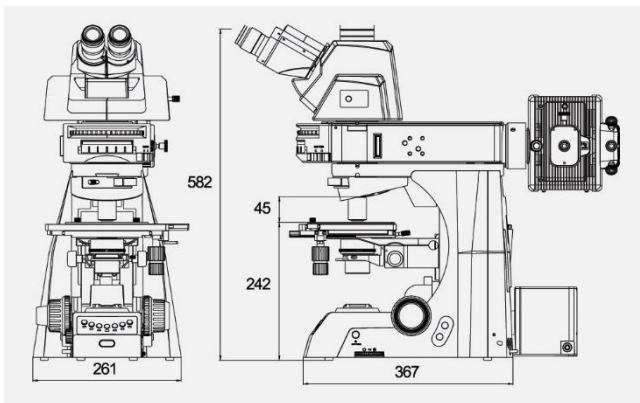

BS-6025TRF

Unit: mm